

Zip HydroTap[®] G4

Boiling | Chilled | Filtered | Instantly | + Hot/Cold

**Commercial All-In-One “non-vented mixer tap” models:
AN160/125G4, AN160/175G4, AN240/175G4**

With new Zip G4 power-saving technology and Zip 0.2 micron filtration.



New under-sink Zip Command Centre™ leads the world in time-saving and energy-saving technology, reducing standby energy consumption by up to 55% over earlier models of similar capacity.



Swivel action spout services both bowls of a double-bowl sink.

Typical Specification

“Under-sink boiling and chilled filtered water appliance with input from both hot and cold mains water supplies, and equipped with integral hot/cold mixer and integral 5 bar pressure limiting and dual check valve, 0.2 micron water filter, air cooled refrigeration system with cleanable lint filter, an interactive touch screen display with password protection and two boiling-water safety modes.”



Hot and cold water plus boiling and chilled filtered water, with input from both hot and cold water supplies.

Single swivel-action tap provides hot, cold, boiling and chilled water to both bowls of a double-bowl sink.

Input from both hot and cold “mains” water supplies, for sites requiring abundant supplies of hot water.

Adjustable water temperature: boiling water 100°C to 68°C, chilled water 5°C to 14°C. **Power-Pulse™ electronic technology** controls the set boiling water temperature within 0.2°C.

Choice of fingertip control for fast cup filling (lever down) or **hands-free** pot filling (lever up).

Two safety modes. Can be set to require finger-thumb operation for boiling water access, eliminating the risk of accidental use. Can also be set to “hot isolation mode” for added safety.

Low-energy lights signal when boiling water is ready, chilled water is ready, or filter change is due.

Hidden light sensor sends appliance to sleep to conserve energy whenever the room goes dark.

Sleeps at 64°C or powers OFF after 2 hours of non-use.

Plus inbuilt 24/7 on/off timing allowing power to be turned off for weekday or weekend periods.

Zip 0.2 micron filter puts crystal-clear, better-tasting water on tap, filtering out chlorine taste and odour, lead and impurities as tiny as one five-thousandth of a millimetre, including protozoan cysts such as Cryptosporidium but does not remove beneficial fluoride.

Zip HydroTap All-In-One “non-vented mixer tap” models with new Zip G4 power-saving technology.

Model	Boiling Cups/hr	Chilled glasses/hr	Rating (kW) @ 230 V	Dimensions W x D x H (mm)
AN160/125G4	160	125	2.05	450 x 470 x 335
AN160/175G4	160	175	2.1	450 x 470 x 335
AN240/175G4	240	175	2.1 + 2.2 (a)	450 x 470 x 335

Standard Cup = 167 ml. Standard Glass = 200 ml.

a) Model AN240/175G4 is installed with an externally mounted 2.2 kW booster unit and must be connected to two separate 13 amp fused spurs.

Boiling System

Open outlet, vented system, factory set to operate at 98°C.
Flow rate 4.0 l/min.

Chilling System

Fan-cooled condenser type, factory set to operate at 5-9°C.
Flow rate 4.0 l/min.
Refrigerant R134a.

Location

Tap must be positioned so that it drains into a suitable sink. Tap should be situated as closely as possible to directly above the under-sink Command Centre. Maximum distance from the base of the tap to the Command Centre is one metre. Command Centre must have clearances as shown on the drawings. Ventilation accessories (supplied) must be installed as per instructions.

Plumbing

Must be installed in accordance with UK Water Supply Regulations. Designed for direct connection to a potable (drinkable) cold water supply with a minimum pressure of 0.7 bar (1.7 bar if fitted with booster unit or scale filtration).
A 5 bar pressure limiting valve is fitted internally. An isolating valve should be installed between the water supply and the Command Centre.

Electrical

Installation must comply with current IEE regulations.
Models 160/125 and 160/175 to be wired to a double pole 13 amp fused spur.
Model 240/175 is installed with an externally mounted 2.2kW booster unit and must be connected to two separate double pole 13 amp fused spurs.

Caution

In hard water areas where mineral scale accumulation may be an issue, consideration should be given to the maintenance required. We recommend use of the Zip Professional high performance limescale filtration system.

Accessories

ZT402 – Zip 0.2 micron replacement filter.

Approvals

CE Endorsed.

Technical Support

Contact Zip on
Tel: 0845 6 005 005
e-mail: service@zipheaters.co.uk

Five Year Warranty

Appliance warranty
24 months, plus additional
36 months tank warranty.
See website for details.

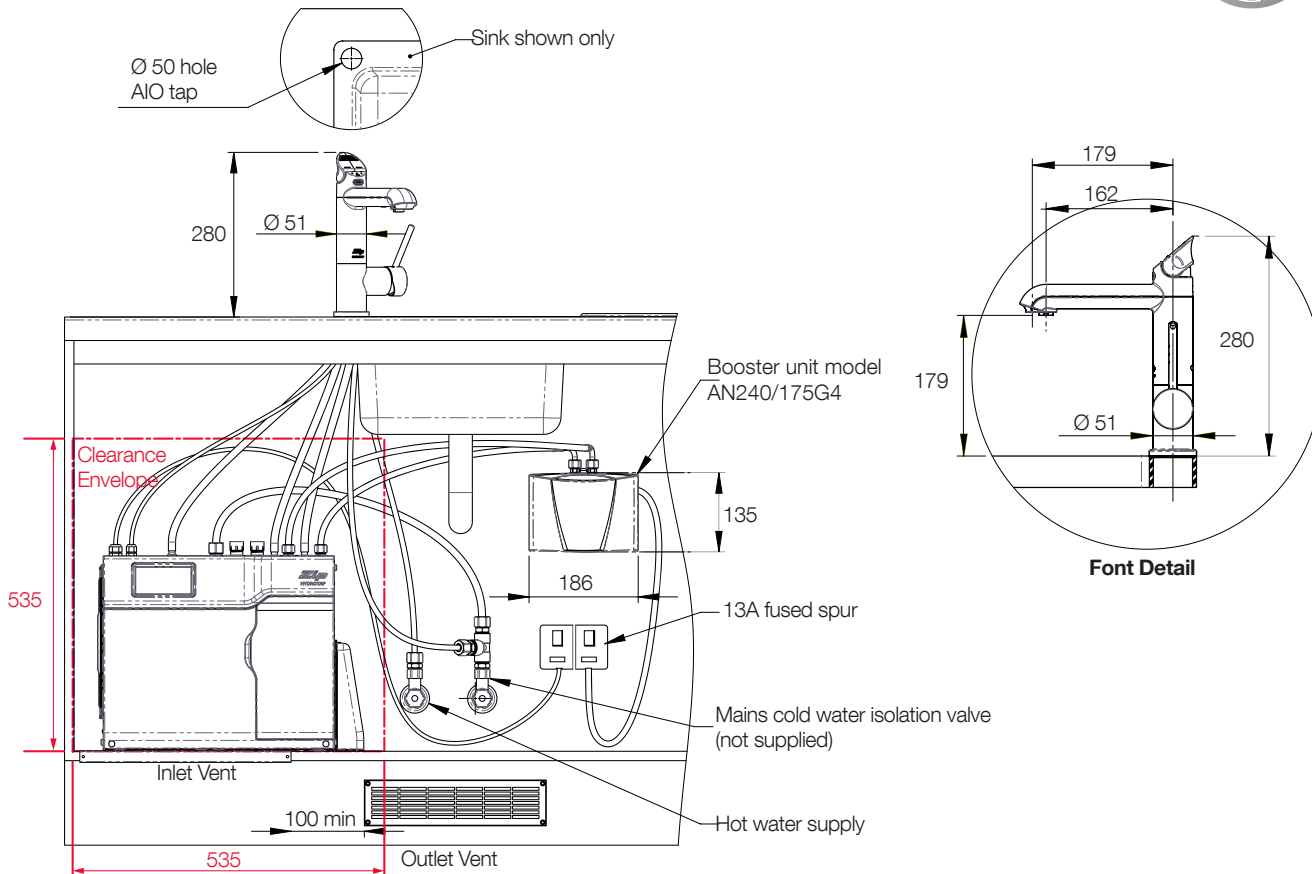

Dimensions in mm.