

Installation, Maintenance and User Instructions

# ZIP Aquapoint III

Direct unvented water heaters

Models: AP3/05, AP3/05/OB, AP3/10,  
AP3/10/OB, AP3/15, AP3/15/OB.



The terms 'Zip' and 'Aquapoint' are registered trademarks

Zip Heaters (UK) Ltd  
14 Bertie Ward Way  
Dereham  
Norfolk  
NR19 1TE

Telephone: 0845 6 005 005 / 0345 6 005 005  
Fax: 01362 692448  
Web: [www.zipheaters.co.uk](http://www.zipheaters.co.uk)



November 2014 V1.02



Instant Boiling Water

Please read these instructions carefully before commencing installation of this unvented water heater. Please leave these instructions with the end user after installation.

# Contents

<b>Approvals</b>	1
<b>Description</b>	2
<b>WARNINGS</b> ⚠	3
<b>CAUTIONS</b> ⓘ	4
<b>Packed Contents</b>	4
<b>Accessories</b>	4
<b>Dimensions</b>	4
<b>Technical Data</b>	5
<b>Spare Parts</b>	6
<b>Installation</b>	7
Requirements	7
Positioning	8
Wall Mounting	8
<b>Plumbing and safety control arrangement</b>	9
<b>Installation Diagrams</b>	10
<b>Electrical installation &amp; wiring</b>	11
Wiring Diagram	11
Safety Cut-Out	11
<b>Commissioning &amp; Operation</b>	12
<b>Maintenance</b>	13
Precautions	13
Schedule	14
De-installation	14
<b>Fault finding</b>	15
<b>Warranty</b>	16

Please read these instructions carefully before commencing installation of this unvented Water Heater.

Installation must only be undertaken by a competent person, familiar with unvented electric water heaters.

The Zip Aquapoint III must be installed in accordance with these instructions and all current legislation, codes of practice and regulations governing the installation of unvented hot water cylinders in force at the time of installation.

Please leave these instructions with the end user after installation. To ensure you have a copy of the latest instructions visit [www.zipheaters.co.uk](http://www.zipheaters.co.uk)

## Approvals

The Aquapoint III models are approved to the LVD and EMC directives and CE endorsed. The Aquapoint III models have been examined, tested and found when correctly fitted to comply with the requirements of the United Kingdom Water Regulations / Byelaws (Scotland). The products are listed under the WRAS (Water Regulations Advisory Scheme) Water Fittings and Materials Directory.

These instructions refer to the following models:

Capacity:	Underbasin	Overbasin
5 Litre	AP3/05	AP3/05/OB
10 Litre	AP3/10	AP3/10/OB
15 Litre	AP3/15	AP3/15/OB

## Description

These instructions will guide you through the installation, maintenance and use of the Zip Aquapoint III, however, if you require any further information please call Zip customer service on 0845 6 005 005 / 0345 6 005 005.

- The Zip Aquapoint III is an unvented water heater designed for connection directly to incoming mains water supply and can serve one or more outlets using conventional taps.
- Care should be taken that the unit being chosen can meet the demands of the outlets being supplied.
- The casing is constructed of impact resistant plastic and heat losses are minimised by the high efficiency polyurethane foam insulation.
- The inner vessel is constructed from glass enamelled steel sheet and pressure tested to 1.2 MPa (12 bar).
- A manually resettable safety cut out automatically cuts off the electrical supply to the heating element in the event of a malfunction.
- A sacrificial magnesium anode is fitted to the vessel to provide anti-corrosion protection for the vessel and the heating element.

Gradual erosion of the anode will occur depending on local conditions and in extreme cases, conditions may cause rapid erosion resulting in particles being deposited as a residue or emitted from the heater.

The Aquapoint III should not therefore, be used in applications where the quality of the water is paramount. Regular preventative maintenance inspections are vital to achieve optimum performance and durability of the appliance.



The condition of the anode should be checked regularly by an authorised Zip service provider as part of the preventative maintenance programme.

**If the hot water system is not used for two weeks or more, it is recommended that a hot tap be turned on for several minutes at a sink, basin or bath, it is not recommended that either a dishwasher, clothes washer or other appliance be used before the heater is returned to service.**

**IMPORTANT:**

**PLEASE READ THESE INSTRUCTIONS CAREFULLY.**

**NOTE THE SAFE OPERATIONAL REQUIREMENTS, WARNINGS AND CAUTIONS. USE THIS PRODUCT CORRECTLY AND WITH CARE FOR THE PURPOSE FOR WHICH IT IS INTENDED. FAILURE TO DO SO MAY CAUSE DAMAGE AND/OR PERSONAL INJURY, AND WILL INVALIDATE THE WARRANTY. RETAIN THESE INSTRUCTIONS FOR FUTURE USE.**

<b>WARNING:</b>		Situations that could cause injury to yourself or others.
<b>CAUTION:</b>		Situations that could cause damage to your appliance or other equipment.
<b>NOTE:</b>		Notes, usage tips or additional information.

## Safety Information

### WARNINGS

- **Installation, commissioning and maintenance of this appliance must only be carried out by a competent installer who will then be responsible for adhering to all relevant standards and regulations.**
- **The appliance must be disconnected from mains power supply before carrying out any work involving live circuits.**
- The appliance must be permanently connected to the supply through an isolating switch with a contact separation of at least 3mm in all poles and be protected by a suitably rated RCD.
- To protect the appliance, an MCB (miniature circuit breaker) or cartridge fuse must be fitted with a rating suitable for the nominal current of the appliance.
- The cross sectional area of the connection cable must be appropriate for the power rating and location of the appliance. See Technical Data.
- The connecting cable must be adequately secured.
-  This appliance must be earthed at all times.
- Check that the power supply is switched off prior to electrical connection.
- The appliance, its wiring and piping must not be modified in any way.
- In case of malfunction isolate the power supply immediately. In case of leaks also isolate the water supply. Repairs must only be carried out by Zip Heaters (UK) Ltd or an authorised Zip service engineer.
- Temperatures in excess of approximately 43°C are perceived as hot, especially by children, and may cause a feeling of burning.
- This appliance must not be used by any person (including children) with limited physical, sensorial or mental abilities or failing experience and/or knowledge unless they are supervised by a person responsible for their safety or have received instructions about how to use the appliance.

## CAUTIONS

- Children should be supervised in order to make sure that they do not play with the appliance.
- The appliance must not be subjected to pressure exceeding 0.55 MPa (5.5 bar). For supply pressures exceeding 0.35MPa (3.5 bar) it is recommended that a pressure reducing valve be installed.
- The appliance must only be used when correctly installed and in perfect working order.
- The appliance must be installed in a frost-free room and must never be exposed to frost.
- The appliance must be completely filled with water before being switched on.
- The Aquapoint III is intended for connection to mains supply only. In any other case please contact Zip on 0845 6 005 005 / 0345 6 005 005 for advice.
- **Zip Heaters (UK) Ltd cannot be held liable for any damages caused by failure to observe these instructions.**
- It is recommended that an **HE45004** Water Block is fitted in the water supply line to minimise the potential damage in the event of any leakage.

## Packed Contents

Please check that the items below have been supplied in the Heater Unit package.

Wall Bracket	x1
Fixing Screws	x2
Rawlplugs	x2
Expansion Relief Valve(1/2" BSP)	x1

## Accessories :

AQ1: Temperature and Pressure relief valve.

AQ2: Expansion vessel and Check valve.

AQ3: Combined pressure reducer and line strainer.

AQ4: Thermostatic blending valve complete with 2 check valves.

HE45004: Water block.

## Dimensions

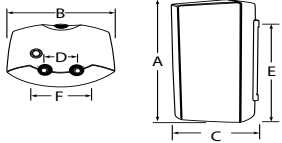
Model	Capacity (litres)	Dimensions (mm)				Fixing Centres (mm)		
		A	B	C	D	E	F	
AP3/05(OB)	5	376	256	260	100	252	140	
AP3/10 (OB)	10	480	350	265	100	378	140	
AP3/15 (OB)	15	480	350	310	100	378	140	

## Technical data

Model	AP3/05(OB)	AP3/10 (OB)	AP3/15 (OB)
Nominal supply voltage	1/N/PE 230V~		
Power rating (kW)	2.0		
Rated Current (A)	8.7		
Element type	Embedded Rod		
Water vessel	Glass enamelled steel tested to 1.2 MPa (12 bar).		
Maximum working pressure	0.55 MPa (5.5 bar).		
Temp. Adjustment range	7°C~75°C		
Capacity	5 Litre	10 Litre	15 Litre
Weight (kg) Full	12.7	18.5	24.8
Weight (kg) Empty	6.7	8.5	9.8
Heat up time (15°C to 65°C)	11 mins	18 mins.	32 mins.
Re-heat time (70% vol.)	7 mins.	12 mins.	18 mins.
Heat Loss(kWh/24 hrs)	0.35	0.48	0.62
Connection fitting	1/2" BSP		
Thermal cut out	Manually resettable set to $84 \pm 3^{\circ}\text{C}$ .		
Safety features	Expansion relief valve set to 6 bar (supplied). Provision for optional T&P valve (AQ1 not supplied). Sacrificial anode to protect vessel and element.		
Protection class	IP24		

All data quoted at nominal supply voltage.

## Spare parts

Item	Description	Part No
1	Element	AQ0330
2	Gasket	AQ0331
3	Control knob lens	AQ0332
4	Thermostat	AQ0333
5	Resettable cut-out	AQ0334
6	Sacrificial anode 10 & 15 litre	AQ0335
7	Sacrificial anode 5 litre	AQ0347
8	Indicator light	AQ0336
9	Control knob with spring	AQ0337
10	Heating flange	AQ0338
11	Anode gasket	AQ0345
12	Insulating bush	AQ0346
	Expansion relief valve (not shown)	EXP0921

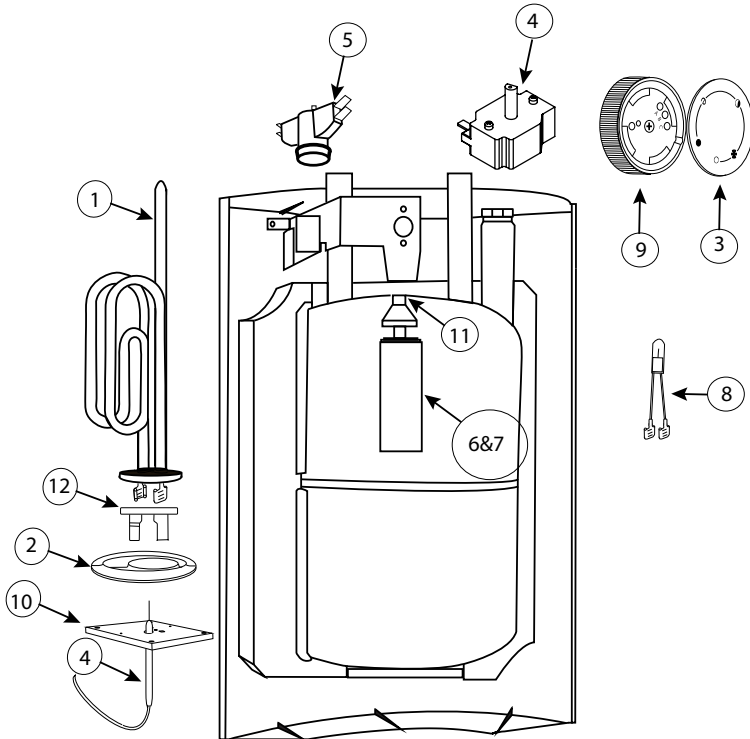

## Installation Requirements

1. Before starting installation the **WARNINGS** ⚠ (page 3) and **CAUTIONS** ⚠ (page 4) should be read and fully understood. If in doubt , or in need of further guidance, please call Zip Customer Service on 0845 6 005 005 / 0345 6 005 005
2. Installations must comply fully with UK Water Regulations, Building regulations part G3 and any Local Authority requirements.
3. The electrical installation including earthing and cross bonding should comply with the current IEE regulations and any local authority requirements.
4. The Zip Aquapoint III is designed for connection direct to the incoming mains water supply and accommodation must be made for the expanded water that will occur with each heating cycle. Regulations permit expanded hot water to be accommodated within the supply pipe work provided that no check valve, stop valve with loose jumper or other fitting can prevent reverse flow. [See diagram 1, (fig.2) on page 10].
5. Where the expanded water cannot be accommodated in the pipe work and the static water supply pressure is under 3.5 bar, fit accessory pack AQ2 (expansion vessel and check valve). Where static water pressures are likely to exceed 3.5 bar fit accessory pack AQ2 and AQ3 (pressure reducing valve and line strainer). [ see diagrams 2&3 (fig2) page 10]
6. If required a temperature and pressure relief valve (accessory AQ1) can be used with any installation by fitting securely into the locating point provided.
7. The 6 bar expansion relief valve must be fitted on the cold water supply. Under no circumstances should the expansion relief valve be installed in an inverted position as fouling of the seat caused by deposits may prevent it from operating correctly. The safety relief valve connections should not be used for any other purpose and no valve should be fitted between the expansion relief valve and the storage cylinder.
8. The drain connection from the expansion relief valve and the T&P valve, if fitted, must be in accordance with the water supply regulations. The point of discharge must be in a safe and visible position. The connection should be made using 15mm pipe having a continuous fall to a maximum length of 3 metres. It shall not have more than 3 right-angled bends. If a waste connection in excess of 3 metres is necessary, the pipe diameter should be 22mm with continuous fall and no more than 4 right-angled bends with a maximum resistance to flow equivalent to 9 metres of straight pipe.
9. An isolating valve must be fitted to the cold water supply.
10. Valves and fittings must be of a type required by the Water Supply Regulations.



## Positioning

1. The Zip Aquapoint III must be installed vertically. The connections should be at the rear of the unit. When facing the heater the hot supply (red) is to the left and the cold supply (blue) is to the right.
2. The heater may be mounted above or below the intended outlets providing the water connections for the undersink models are at the top and for the oversink models underneath.

### **NB. Undersink and oversink models are not interchangeable.**

The fixings must be capable of supporting the heater when full of water (see Technical data page 5).

3. The undersink unit can be placed unsupported on the floor or cupboard base, but if additional support is required, securing screws are supplied that locate to the rear of the casing. [As shown in (fig.1)]
4. Always position the Zip Aquapoint III to allow for its removal for future inspection and Maintenance.
5. The Zip Aquapoint III is not recommended for installation above false ceilings.
6. Do not install in a location where this unit or connecting pipelines can freeze.
7. When considering the location of the heater, consideration should be given to the safe and visible disposal of any water resulting from leaks and seepage.

This is particularly relevant when the heater is located in a roof space, cupboard or any concealed location. For guidance please call Zip Customer Service on 0845 6 005 005 / 0345 6 005 005.

## Wall Mounting

fig. 1

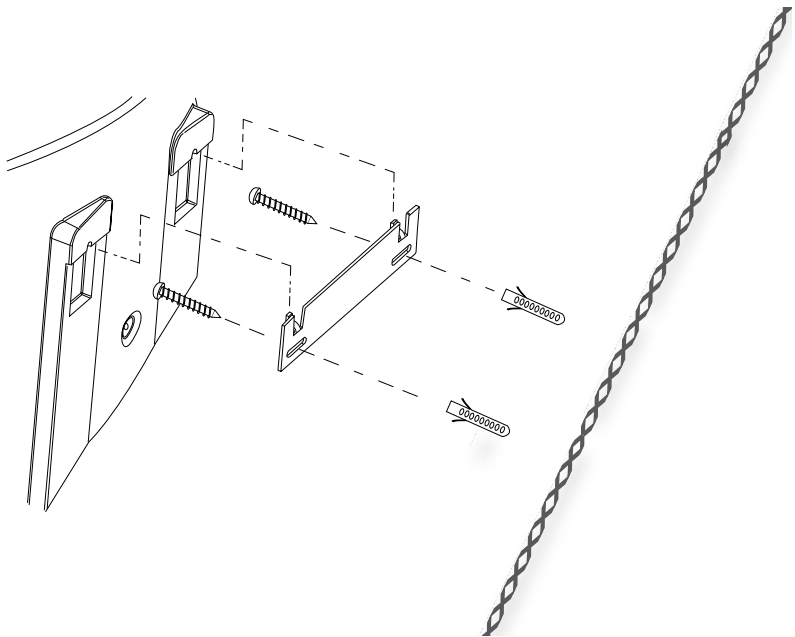

The unit will be supported by being hung on a bracket fixed to a support wall, using the fixings provided, as shown (fig.1). Therefore it is important to ensure that the wall is strong and solid enough to fully support the unit when the tank is full.

It is important to ensure when drilling the wall, that the selected position avoids any pipe work or electrical cabling. To mount the heater, the bracket 'hooks' locate into the slots provided in the back of the unit, allowing the unit to hang flat against the wall.

**IT IS NOT NECESSARY TO REMOVE THE CASING TO MOUNT THE WATER HEATER ON THE WALL BRACKET.**

**Plumbing and safety control arrangement**

1. Check the incoming water supply pressure with reference to the table and diagrams on the following page to determine the layout required bearing in mind that mains water supply pressure can increase considerably at night.
2. Refer to the diagrams in (fig.2) to determine the accessories required to suit your layout
3. Position the heater and controls to allow for future maintenance.
4. All control and safety valves are marked with the direction of flow and will not function if incorrectly orientated. Do not break any seals or attempt to adjust any safety valve, to do so may impair the safety of the installation and will invalidate the warranty.
5. To ensure a watertight seal use fibre washers for connecting the inlet and outlet pipes to the heater. Complete the seal by using PTFE tape to the threads but do not over apply or extend beyond the thread limits as this will lessen the effectiveness of the joints. Do not use plumbers paste to secure the joints as this can impair the operation of any valves connected to the heater.
6. An isolating service valve (not supplied) should be fitted in the cold water supply pipe work as shown in all 3 diagrams in (fig.2).
7. Flush all pipe work thoroughly before making the final connections to the valves, accessories and cold feed to the heater to ensure that any debris is removed. Failure to do this may result in irreparable damage to the controls and will invalidate the warranty.

# Installation diagrams (Underbasin model shown)

fig.2

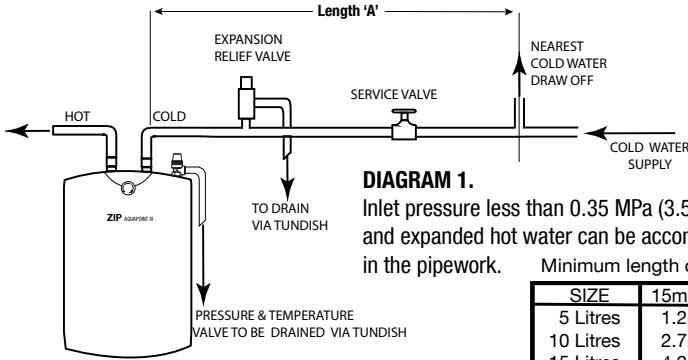

Minimum length of pipe (Length 'A').

SIZE	15mm Pipe	22mm Pipe
5 Litres	1.2m (4ft)	0.6m (2ft)
10 Litres	2.7m (9ft)	1.2m (4ft)
15 Litres	4.2m (14ft)	1.8m (6ft)

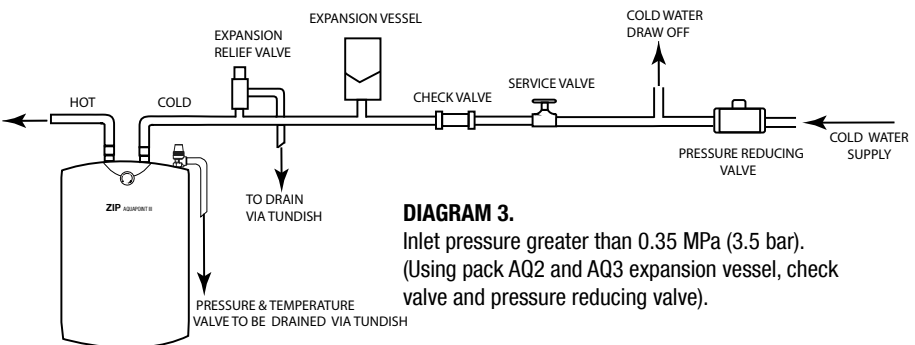
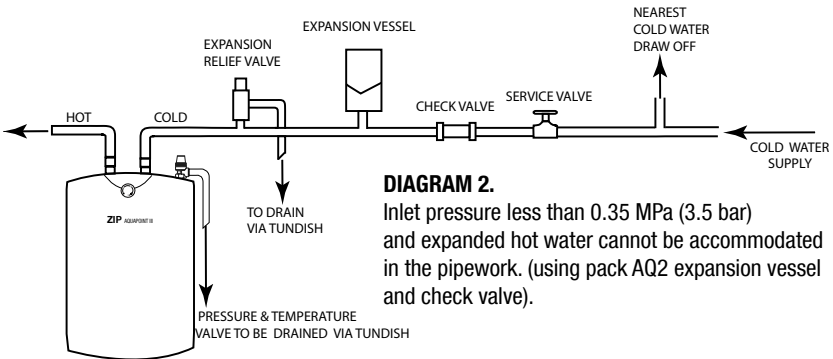

## Electrical installation & wiring

It is recommended that the electrical installation is carried out by a qualified electrician. It is essential that the electrical installation including earthing and cross bonding should be carried out to comply with the current IEE regulations and local council requirements.

**WARNING:** ⚠️ **SWITCH OFF THE MAINS ELECTRICAL SUPPLY BEFORE CARRYING OUT ANY WORK INVOLVING A LIVE CIRCUIT. 230v AC SUPPLY ONLY, THIS APPLIANCE MUST BE EARTHED.**

1. The Zip Aquapoint III is pre-wired with a length of 3 core cable suitable for connection to a mains 230v supply. Connection must be made in accordance with the current IEE wiring regulations to a double pole isolating switch on a dedicated circuit or a double pole switched spur.
2. If the cable length is insufficient it is recommended that the entire length of cable is replaced with no joins to the original. To replace the cable:
  - a) Prise the temperature control knob off the spindle and remove the screw underneath.
  - b) Release the two fixing screws at the top of the cover assembly.
  - c) Remove the cover by lifting forwards and upwards.
  - d) Release the locknut on the cable grommet assembly.
  - e) Remove the existing cable and pass the new cable through the grommet assembly.
  - f) Remake the cable connections and tighten the grommet locknut to ensure the cable is securely clamped
  - g) Re-assemble the cover.
3. All internal wiring is factory mounted and should not be altered or modified.

**This appliance must be earthed.**

**Do not switch on the electrical supply until the water heater is full of water.**

### Wiring Diagram

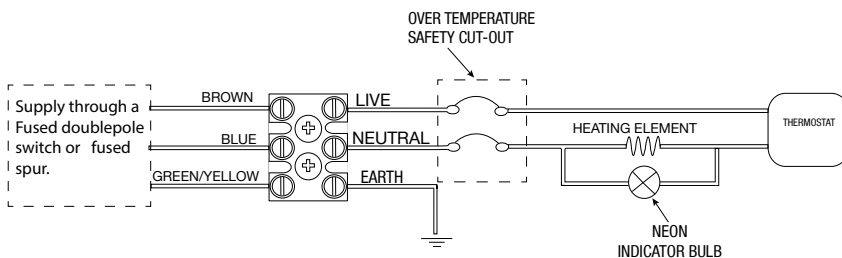

### Safety Cut-out

In the event of a malfunction that leads to an over temperature situation, a Safety cut out will automatically cut off the electrical supply to the element.

This is a manually resettable cut-out that may be reset by a qualified electrician once the fault has been corrected.

## Commissioning & operation

1. Check that all 'Requirements' under 'Installation' have been met.
2. Check that all water and electrical connections are correct and tight.
3. Open a hot water tap.
4. Open the water mains isolating valve and allow the heater to fill.
5. Close the hot water tap when water starts to flow from it. (The heater vessel should now be full).
6. Check for leaks and rectify as necessary.
7. Manually operate the Expansion Relief Valve and T&P Valve if fitted to ensure free water flow through the discharge pipe by turning the knob to the left and holding it in the open position.
8. Set the temperature control knob to the required position. The 'E' position with a water temperature of 55°C is recommended for economical operation while minimising lime-scale deposits and thermal losses.

### Note:

- Rotating the temperature control knob varies the temperature over the range 7°C to 75°C.
- The maximum temperature can be limited by prising the front cover (lens) off the temperature control knob and re-positioning the limit pin as shown in (fig.3) below, from '0' to position 'A' max 55°C, 'B' max 45°C, or 'C' max 35°C.
- Hot water at 55°C or more can scald.

### Note.

To protect the water heater from freezing, the temperature control knob may be set \* when a stored water temperature of approximately 7°C will be maintained while the heater is connected to the power supply.

**NB:** This protection does not extend to the pipe work and fittings.

fig.3

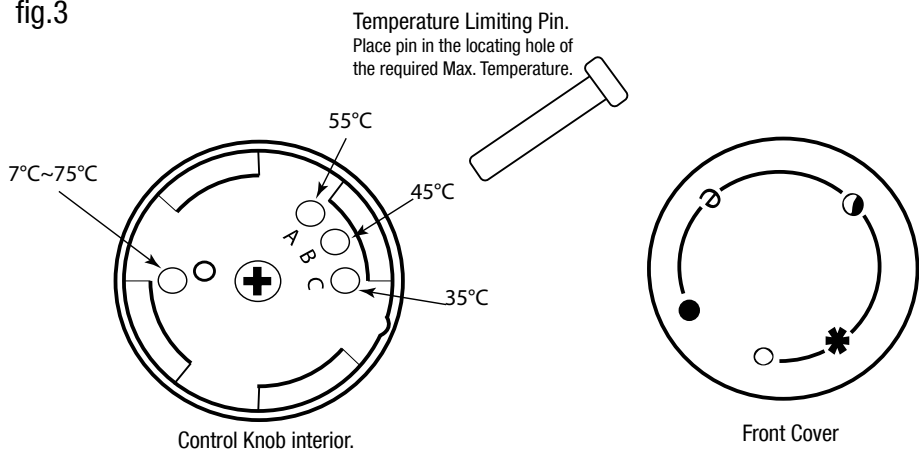

9. Switch on the electrical supply to the unit. The red neon light will glow during the heating cycle and will extinguish when the selected temperature is reached re-lighting again for the next heating cycle.
10. During the heating cycle no water should escape to waste from either the expansion relief or T&P valves.
11. Allow the heater to reach the selected temperature and when the indicator light has extinguished, check the water temperature and re-check the water connections adjusting as necessary.
12. Please pass these instructions on the person responsible for the building and it's management.

## **Maintenance**

### **Precautions**

1. The Zip Aquapoint III is an unvented electric water heater and only a competent person (electrician or plumber), familiar with unvented systems, should carry out any servicing and maintenance work on this unit.
2. DO NOT Remove the cover whilst the unit is connected to the electrical supply.  
**WARNING** ⚠ When the neon indicator light is extinguished the unit is still connected to the electrical supply, only by operating the 'double pole isolating switch' can the unit be disconnected from the supply.
3. The over temperature safety cut-out reset is located inside the cover. DO NOT reset the over temperature cut-out until the cause of it's operation has been correctly diagnosed and corrected.
4. DO NOT use the water heater if it is suspected of being frozen. Switch off the electrical supply if water ceases to flow and do not switch it back on until a competent person (electrician or plumber), has checked that it is safe to do so.
5. The heater should be visually inspected regularly. This is particularly important if the heater is located in a cupboard, roof space or any other concealed location. If there are any signs of leaks or seepage the heater should be isolated from the water supply and switched off from the electrical supply until a competent person (electrician or plumber), has investigated the cause.
6. DO NOT block or restrict the discharge from any safety valve.
7. DO NOT tamper with any safety valve.
8. If water discharges from any safety valve, switch off the electrical supply to the unit, isolate the water supply and contact a competent person (electrician or plumber) familiar with unvented systems.
9. Please note that limescale forms more readily at higher temperatures. Damage or failures caused by the formation of limescale are specifically excluded under the terms of the warranty. To reduce limescale formation to a minimum the unit should always be operated at the lowest convenient temperature. The 'E' temperature setting is recommended.

## Schedule

It is recommended that all key components of the heater should be inspected on a regular basis, no greater than 12 monthly intervals, for the continued safe and efficient operation of the unit. The inspection should be carried out by a competent person (electrician or plumber) familiar with unvented systems and the components to be inspected should include the following:

1. Sacrificial anode. The condition of the anode should be checked regularly by an authorised Zip service provider as part of the preventative maintenance program, to ensure it's effectiveness in protecting the vessel and element from corrosion.  
To check the condition of the anode visually through the flange opening, first remove the thermostat temperature probe and disconnect the electrical wires to the element before unscrewing the element assembly and removing it.  
To check the condition of the anode electrically, disconnect the wire between the anode and the vessel and check that the current between anode and vessel exceeds 0.4mA. Ensure that the wire is reconnected afterwards.  
If the current between the anode and the vessel does not exceed 0.4mA it should be checked visually and if badly corroded, it should be replaced.  
To replace the anode, grasp it with long tongs or another suitable tool through the flange opening and unscrew the securing nut whilst, at the same time supporting the anode from inside the vessel.
2. Expansion relief valve. Check correct operation.
3. T&P relief valve, if fitted. Check correct operation.
4. Expansion vessel, if fitted. Check pressure-referring to label on the side of the vessel.
5. Integral line strainer, if a pressure reducing valve is fitted. Inspect and clean as necessary.
6. Check the discharge pipe is free of obstructions.
7. Check that all the electrical connections are tight.

## De-Installation

- Switch off and disconnect the electrical supply.
- Close the mains water supply isolating valve.
- Disconnect the inlet and outlet connections on the heater.
- Remove the heater.
- Drain the unit through the hot water supply connection.

## Fault Finding

Fault	Possible cause	Solution
Over temperature cut-out operates.	The thermostat has failed.	Reset and if the cut-out operates again, isolate the unit and contact the installer. <b>NB. Isolate the electrical supply before removing the cover and ensure that the cover is correctly replaced and secured before reconnecting.</b>
	The thermostat is set at too high a temperature.	
Regular, intermittent water discharge from the tundish.	Loss of pressure from the expansion vessel.	Isolate the heating system and the mains cold water supply. Partly drain the unit. Recharge the expansion vessel to the specified pressure and re-commission.
	Thermostat failure.	Isolate the heating system and check the thermal controls when discharge ceases. Replace the thermostat if faulty.
Continuous water discharge from tundish.	Pressure reducing valve not operating correctly.	Check with pressure gauge and replace as necessary.
	T&P relief valve not operating correctly.	Check and replace if faulty.
	Expansion relief valve not operating correctly.	Check and replace if faulty.
No water flow from hot taps.	Cold water mains is isolated.	Check and switch on.
	Integral line strainer in pressure reducing valve is blocked.	Check and clean as necessary.
	Pressure reducing valve is incorrectly fitted.	Refit correctly with arrows in the direction of flow.
Water from hot taps is cold.	Power supply not switched on	Check and switch on.
	Over temperature cut-out has operated.	See fault 'Over temperature cut-out operates' above.
	Faulty element.	Check and replace as necessary.
	Thermostat failure.	Check and replace as necessary.



## Warranty

The Zip appliance you have chosen is precision-built from the finest materials available and should give many years of trouble free service.

Certain warranties may be implied by law into your contract with Zip.

The warranty provided below is additional to these implied warranties and nothing set out below shall limit your statutory rights or rights at law.

Zip Heaters (UK) Ltd warrants that, should any part fail within 12 calendar months of installation, that part will be repaired or replaced free of charge by Zip or its Distributor or Service Provider, except as set out below, provided the appliance is installed and used strictly in accordance with the instructions supplied, and that failure is not due to accident, misuse, abuse, unsuitable water conditions, or to any alteration, modification or repair by any party not expressly nominated by Zip.

No costs are payable by the customer other than any mileage or travelling-time charges incurred by a Zip Service Provider or the cost of removal, cartage and re-installation of any component of the appliance if it needs to be returned for repair to Zip or its Distributor.

This warranty does not cover damage resulting from non-operation of the appliance or consequential damage to any other goods, furnishings or property.

Zip does not exclude, restrict or modify any liability that cannot be excluded, restricted or modified or which cannot, except to a limited extent, be excluded, restricted or modified as between the owner or user and Zip under the laws applicable.

Furthermore, this warranty does not displace any statutory warranty, but, to the extent to which Zip is entitled to do so, the liability of Zip under any statutory warranty will be limited at Zip's option to the replacement of the appliance or supply of equivalent appliance, the payment of the cost of replacing the appliance or acquiring an equivalent appliance, or the payment of the cost of having the appliance repaired or the repair of the appliance.

**NOTE:** It is our policy to continually improve products and as such we reserve the right to alter data, specifications and component parts without prior notice.

To ensure you have the latest revision of this instruction manual, please visit [www.zipheaters.co.uk](http://www.zipheaters.co.uk) to download the latest copy.

**IMPORTANT:** No liability is accepted for incorrect use of this product.