



Installation & Maintenance Instructions



The Electric Heating Company Ltd
Unit 40 Block 5 Third Road
Blantyre Industrial Estate
Blantyre Glasgow
G72 0UP
Tel: 01698 820533
Fax: 01698 825697
email: info@electric-heatingcompany.co.uk

IMPORTANT NOTE TO THE INSTALLER

Read these instructions before commencing installation. Unvented cylinders are a controlled service as defined in the latest edition of the building regulations and should only be fitted by a competent person.

The relevant regulations are: England and Wales - Building Regulation G3, Scotland - Technical Standard P3, N Ireland - Building Regulation Part F

After installation the commissioning record list must be completed and left, with these instructions, with the householder for future reference.

PAGE	CONTENT
1	Introduction
2	Storage, Handling & Supply Requirements
3	Component Table
4	Siting the unit
5	General Installation
7	Discharge Arrangement
9	Technical Specifications: Slimline - Direct & Indirect
10	Technical Specifications: Direct & Indirect
11	Technical Specifications: Solar Indirect
12	Solar Coil Installation
13	S-Plan Wiring Schematics
14	Commissioning & Servicing
15	Fault Finding & User Instructions
16 - 17	Specification & Performance
18	Commissioning Record
19-24	Service Record
25-26	Guarantee - Terms & Conditions
27	Gaurantee Card

INTRODUCTION

The EHC Neptune Unvented cylinder is made from Duplex Stainless Steel for excellent corrosion resistance. The EHC Neptune has a strong rust-resistant steel case and is highly insulated with environmentally friendly foam.

The EHC Neptune is supplied complete with all the necessary safety and control devices needed to connect to the cold water mains. All are pre-adjusted. High quality controls have been selected to combine high flow rate performance with minimum pressure drop to make the EHC Neptune perform well in all areas, even those with poor water pressure.

IMPORTANT NOTE TO THE INSTALLER



Read these instructions before commencing installation. Unvented cylinders are a controlled service as defined in the latest edition of the building regulations and should only be fitted by a competent person.

The relevant regulations are: England and Wales - Building Regulation G3, Scotland - Technical Standard P3, N Ireland - Building Regulation Part F

After installation the commissioning record must be completed and left, with these instructions, with the householder for future reference.

STORAGE PRIOR TO INSTALLATION

The EHC Neptune should be stored in its original packaging in an upright position in an area free from excessive damp. Regulations G3+L.

HANDLING PRODUCT

The EHC Neptune should be carried upright where possible. Assessments of risks for carrying the cylinder should be conducted. Use more than 1 person for carrying where appropriate. Always follow latest guidelines for lifting techniques, to avoid injury and damage to the product.

WATER SUPPLY

The EHC Neptune operates at 3 bar (controlled by the inlet control set) and is capable of delivering over 50 litres per minute. The high quality inlet control set has been designed to make the most of the flow rates available, however the performance of any unvented system is only as good as the mains water supply. The maximum possible water demand should be assessed, taking into consideration that both hot and cold services are supplied simultaneously from the mains.

The water supply should be checked to ensure it can meet these requirements. If necessary, consult the local water company regarding the likely pressure and flow rate availability.

If measuring the water pressure, note that a high static (no flow) mains pressure is no guarantee of good flow availability. In a domestic installation 1.5 bar and 25 l/min. should be regarded as the minimum. The maximum mains pressure that the inlet control set can accept is 12 bar.

Consideration should be given to upgrading existing ½" (15mm) cold mains pipework to a larger size if the recommended minimum pressure/flow rate is not being achieved.

ELECTRIC SUPPLY

The EHC Neptune requires 240 Volt electrical supply for the immersion elements. The electrical supply to each immersion heater must be fused at 13A via a double pole isolating switch to BS 3456. The cable must be at least 2.5mm² heat resistant (85°C HOFr) sheathed flex complying to BS 6141:1981 Table 8.

UNPACKING THE UNIT

The EHC Neptune comes complete with the fittings required to complete the installation. Please see over for component content list.



High flow rate inlet control set - 3 bar
PRV 6 bar Expansion Relief
Spare Part No. CB091



Temperature and pressure relief valve
Spare Part No. CBO98



Acetal tundish 15 x 22 mm
Spare Part No. CBO96



Expansion Vessel
• 60- 250 ltr units - 18 ltr vessel
Spare Part No. CB144
• 300 ltr units - 25 ltr vessel
Spare Part No. CB145



Two port valve
Spare Part No. EC10008



Incoloy long life
3 kW immersion heater
Spare Part No. CBO99



Dual thermostat
Spare Part No. CB142

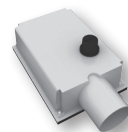

High limit thermostat
Spare Part No. CB135

COMPONENT CONTENT TABLE

	Installation & Maintenance Instructions	Sensor Pocket Retaining Bung	Single High Limit Stat	Dual Thermostat	Two Port Valve	Immersion Heater	Expansion Vessel	Tundish	Temp & Pressure Relief Valve	Inlet Control Set
Slimline Direct Models (Electric)	○					○	○	○	○	○
Slimline Indirect Models	○			○	○	○	○	○	○	○
Direct Models (Electric)	○					○	○	○	○	○
Indirect Models	○			○	○	○	○	○	○	○
Solar Indirect Models	○	○	○	○	○	○	○	○	○	○

Direct Models (Electric)
 Indirect Models (Single Coil)
 Solar Indirect Models (Two Coils)

SITING THE UNIT

The EHC Neptune can supply outlets above it or at some distance from it. Site the unit to minimise “dead leg” distances, especially to the point of most frequent use.

Outlets above the EHC Neptune will reduce the outlet pressure available by 0.1 bar for every 1m of height difference. The unit should be protected from frost. Particular care is needed if sitting in a garage or outbuilding. All exposed pipework should be insulated. EHC Neptune must be installed VERTICALLY on a flat base capable of supporting the weight of the cylinder when full. See technical specification section (page 16) for weights. The minimum recommended cupboard size is 650mm square.

Access for maintenance of the valves should be considered. Consideration should be given to position of discharge pipes (tundish), drain valves - shall be positioned away from electrical components.

The immersion heaters are 375mm long and care should be taken to ensure that they can be withdrawn for servicing if required. The discharge pipework from the safety valves should fall continuously and terminate safely.

SCHEMATIC DIAGRAM

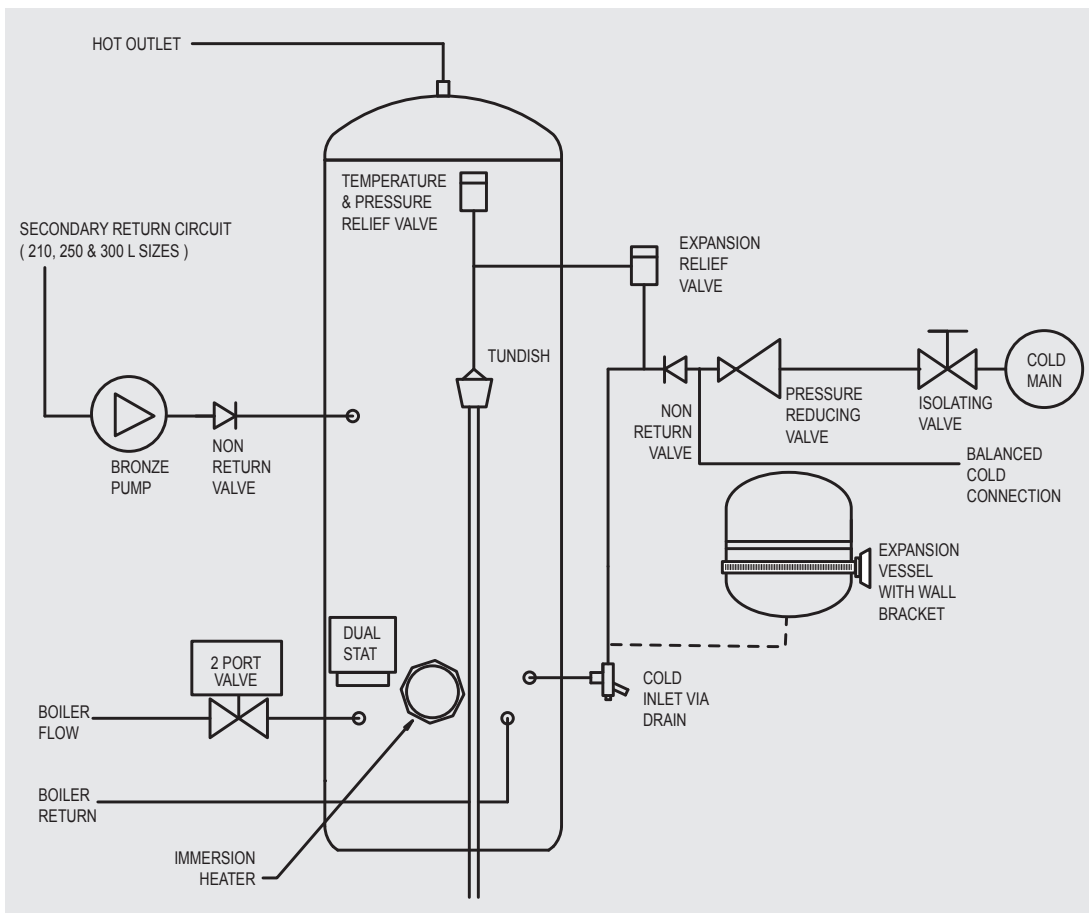

NOTES:

The pressure reducing valve, non-return valve and expansion relief valve are combined together in the inlet control set.

On 60 - 180 litre sizes there is no dedicated secondary return boss and the secondary return circuit should be tee'd into the cold feed pipe just above the drain elbow.

GENERAL INSTALLATION

COLD MAINS PIPEWORK

Run the cold main through the building to the place where the EHC Neptune is to be installed. Take care not to run the cold pipe near hot water or heating pipework so that the heat pick-up is minimized. Identify the cold water supply pipe and fit an isolating valve (not supplied).

A 22mm BS1010 stopcock can typically be used but a 22mm quarter turn full bore valve would be better as it does not restrict the flow as much. Do not use "screwdriver slot" or similar valves. Make the connection to the cold feed of the cylinder and incorporate a drain valve. Position the drain valve no higher than the cold inlet to ensure sufficient draining of cylinder when required. Position the inlet control just ABOVE the Temperature & Pressure Relief Valve (TPRV) mounted on the side of the cylinder. This ensures that the cylinder does not have to be drained down in order to service the inlet control set. Ensure that the arrow points in the direction of the water flow. Select a suitable position for the expansion vessel. Mount it to the wall using the bracket attached to the vessel. Use suitable fittings capable of supporting full vessel weight (and with appropriate consideration to wall material). Connect the expansion vessel to the cold feed pipework between the inlet control set and the cold inlet on the cylinder. Ensure that the top of the vessel is accessible for servicing.



CONNECTING TO THE CYLINDER

All of the pipework connections on the cylinder are 22mm compression and supplied complete with gland nuts and olives, in the Accessory Kit box. Only connect 22mm Table X copper tube to these connections.

Cut the tube with a pipe cutter and ensure no sharp edges or burrs protrude. Slide both gland nut and olive onto the tube and push tube fully home into the connection, ensuring the tube end fully bottoms on the connection recess. Smear the outer wall of the olive with plumbing paste and tighten gland nut in the prescribed manner. Upon filling/commissioning, ensure all connections are completely watertight. Note: No control or isolation valve should be fitted between the expansion relief valve and the storage cylinder. The relief valve connections should not be used for any other purpose.

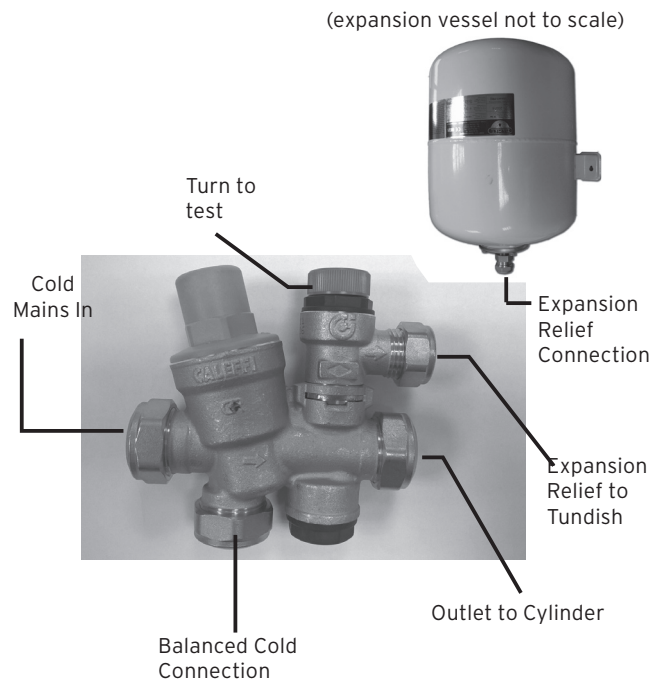



BALANCED COLD CONNECTION

If there are to be showers, bidets or monobloc taps in the installation then a balanced cold supply is necessary. There is a 22mm balanced connection on the inlet set.

HOT WATER PIPEWORK

Run the first part of the hot water distribution pipework in 22mm. This can be reduced to 15mm and 10mm as appropriate for the type of tap etc. Your aim should be to reduce the volume of the hot draw-off pipework to a practical minimum so that the time taken for the hot water is as quick as possible. Where monobloc mixing taps and showers are used, these should be installed to comply with the Water Supply (Water Fittings) Regulations 1999. If these devices are supplied with un-balanced supplies there should be single check valves installed at both inlets, to stop over pressurising of either supply.

PRIMARY COIL CONNECTIONS FOR INDIRECT UNITS

For Solar input models refer to pages 11-12 before making any connections.

Connect the primary connections (Indirect only) using the compression connections provided. The primary circuit must be positively pumped. Gravity circulation is not suitable. Either primary connection may be used as the primary flow, reheat times are not effected. The primary circuit can be open vented or sealed, with up to a maximum pressure of 3.5 bar. If you seal the primary circuit an additional expansion vessel and safety valve is required. The boiler may be Gas, Electric or Oil but must be under effective thermostatic control. Uncontrolled heat sources such as some AGA's, back boilers, solid fuel stoves, etc. are NOT SUITABLE. Please contact our Technical department for guidance. Connect the two port zone valve (indirect only) into the primary flow pipework. The direction of flow arrow should be towards the primary flow connection.

SECONDARY CIRCULATION

The EHC Neptune can be used with secondary circulation. An appropriate WRAS approved bronze circulator should be used in conjunction with a non-return valve to prevent backflow. On large secondary circulation systems it may be necessary to incorporate an extra expansion vessel into the circuit to accommodate the increased system water volume. Secondary circulation should be avoided on Direct electrically heated units being used on off-peak electricity tariffs.

A secondary return boss is fitted as standard on 210, 250 & 300 ltr units. On smaller sizes, tee into the cold feed pipe above the drain.

IMMERSION HEATERS

Only immersion heaters with a thermal cut-out may be used. To help ensure this, the immersion heaters have a special $1\frac{3}{4}$ " thread. They are rated at 3kW at 240V and are of a low noise Incoloy construction.

They have both a thermostat and a high limit cutout. Please order the correct replacement via ourselves; fitting non-approved immersions may affect your guarantee. When fitting, ensure the 'O' ring is positioned correctly on the head of the immersion heater and lubricate before fitting. Fit it by hand until almost home then tighten gently as the 'O' rings will seal easily. The electrical supply to each immersion heater must be fused at 13A via a double pole isolating switch to BS 3456. The cable must be 2.5mm² heat resistant (85°C HOFr) sheathed flex complying to BS 6141:1981 Table 8. Do not operate the immersion heater/s until the unit is full of water. Do not operate the immersion heater/s if any sterilisation liquid is in the cylinder as this will cause premature failure.

ELECTRICAL CONNECTIONS

Complete the wiring - use the appropriate wiring diagrams on page 12- 13.

DISCHARGE ARRANGEMENT

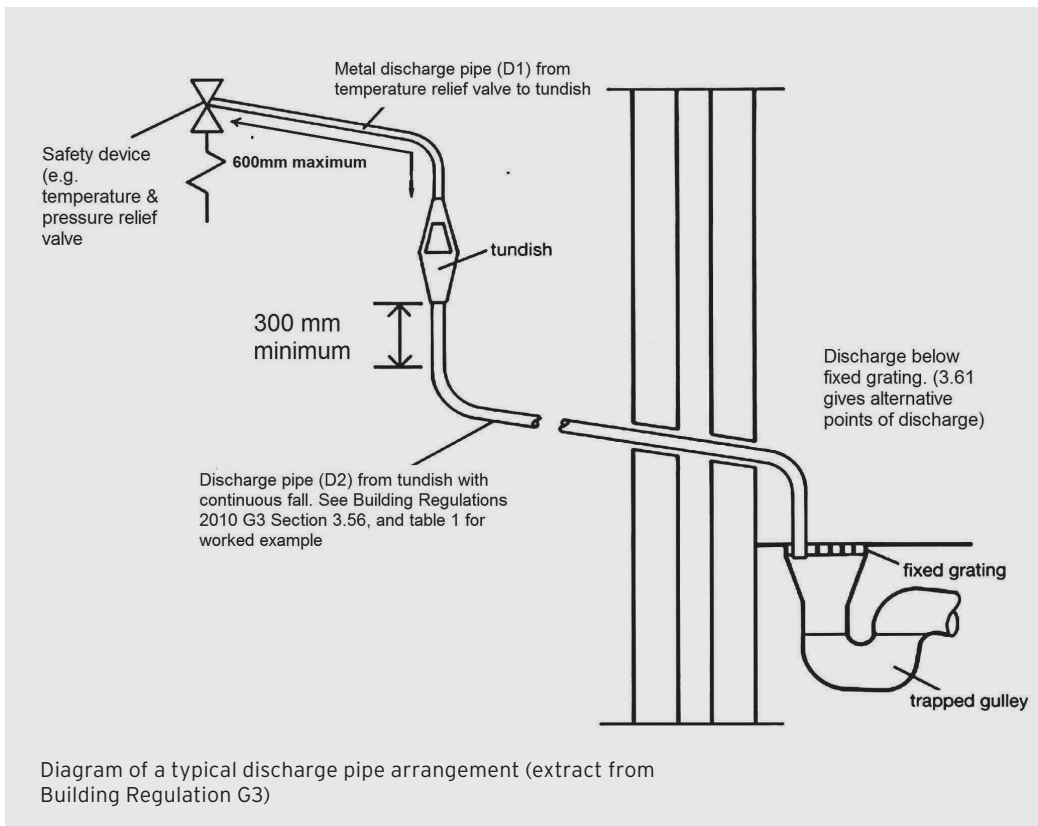

Note: The discharge will consist of scalding water and steam. Asphalt, roofing felt and non-metallic rainwater goods may be damaged by such discharges.

Note: D2 pipe from tundish is now allowed to be installed in soil stacks within premises. This activity is not recommended as discharge from T&P may continue for long periods of time. It is the installer's responsibility to ensure the discharge pipework can support the discharge for prolonged periods. If used follow guidance on mechanical seal without water trap given in G3 Building Regulations. As discharge can be in excess of 90°C discharge into plastic pipework is also not recommended.

Position the inlet control group so that the discharge from both safety valves can be joined together via a 15mm end feed Tee (see diagram above). Connect the Tundish and route the discharge pipe. The discharge pipework must be routed in accordance with Part G3 of schedule 1 of the Building Regulations. The information that follows is not exhaustive and if you are in doubt you should seek advice. The two safety valves will only discharge water under fault conditions. When operating normally water will not be discharged. The tundish should be vertical, located in the same space as the unvented hot water storage system and

be fitted as close as possible to, and lower than, the safety device, with no more than 600mm of pipe between the valve outlet and the tundish. The tundish should be positioned away from electrical devices.

Any Discharge should be visible at the tundish. The tundish should be located such that any discharge is visible. In addition, where discharges from safety devices may not be apparent, e.g. people with impaired vision or mobility, consideration should be given to the installation of a suitable safety device to warn when discharge takes place, e.g. electronically operated.

The discharge pipe (D2) from the tundish should:

- A) Have a vertical section of pipe at least 300mm long, below the tundish before any elbows or bends in the pipework.
- B) Be installed with a continuous fall of at least 1 in 200 thereafter.

The discharge pipe (D2) from the tundish should be of metal or other material that have been demonstrated to be capable of withstanding temperatures of the water discharged.

The discharge pipe (D2) should be at least one pipe size larger than the nominal outlet size of the safety device unless its total equivalent hydraulic resistance exceeds that of a straight pipe 9m long i.e. discharge pipes between 9m and 18m equivalent resistance length should be at least two sizes larger than the nominal outlet size of the safety device, between 18 and 27m at least 3 sizes larger, and so on. Bends must be taken into account in calculating the flow resistance. Refer to diagram 1, Table 1 and the worked example. An alternative approach for sizing discharge pipes would be to follow BS670 ce of services supplying water for domestic use within buildings and their curtilages.

The discharge pipe (D2) should terminate in a safe place where there is no risk to persons in the vicinity of the discharge. Examples of acceptable discharge arrangements are:

- a. To a trapped gully with the end of the pipe below the fixed grating and above the water seal.
- b. Downward discharges at a low level; i.e. up to 100mm above external surfaces such as car parks, hard standings, grassed areas etc. are acceptable providing that where children play or otherwise come into contact with discharges, a wire cage or similar guard is positioned to prevent contact whilst maintaining visibility.
- c. Discharges at a high level; e.g. in to metal hopper and metal down pipe with the end of the discharge pipe clearly visible or onto a roof capable of withstanding high temperature discharges of water and 3m from any plastic guttering systems that would collect such discharges.
- d. Device to warn when discharge takes place.

WORKED EXAMPLE

The example below is for G1/2 temperature relief valve with a discharge pipe (D2) having 4 No. elbows and length of 7m from the tundish to the point of discharge.

From Table 1:

Maximum resistance allowed for a straight length of 22mm copper discharge pipe (D2) from a G1/2 temperature relief valve is: 9.0m. Subtract the resistance for 4 No. 22mm elbows at 0.8m each = 3.2m. Therefore the maximum permitted length equates to: 5.8m. 5.8m is less than the actual length of 7m therefore calculate the next largest size. Maximum resistance allowed for a straight length of 28mm pipe (D2) from a G1/2 temperature relief valve equates to: 14m. As the actual length is 7m, a 28mm (D2) copper pipe will be satisfactory.

TABLE 1

Sizing of copper discharge pipe 'D2' for a temperature relief valve with a G1/2 outlet size (as supplied).

Size of discharge pipework	Maximum length of straight pipe (no bends or elbows)	Deduct the figure below from the maximum length for each bend or elbow in the discharge pipe
22mm	Up to 9m	0.8m
28mm	Up to 18m	1m
35mm	Up to 27m	1.4m

TECHNICAL SPECIFICATIONS

EHC NEPTUNE SLIMLINE DIRECT

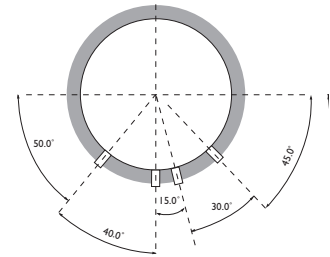
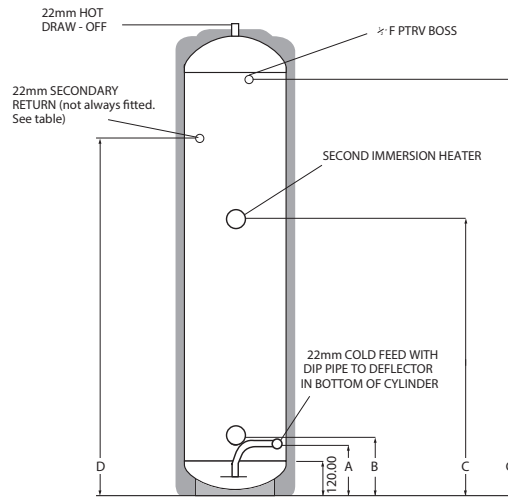

CODE	HEIGHT	DIAMETER	A	B	C	D	G	ERP BAND	LOAD PROFILE	kWH/Annum
NDIRSL90L	1048	478	175	210	610	N/F	858	D	M	1461
NDIRSL120L	1236	478	175	210	710	N/F	1046	D	M	1461
NDIRSL150L	1424	478	175	210	810	N/F	1234	D	L	1778
NDIRSL180L	1674	478	175	210	910	N/F	1484	D	L	2791
NDIRSL210L	1987	478	175	210	1100	1500	1797	D	L	2837

EHC NEPTUNE SLIMLINE INDIRECT

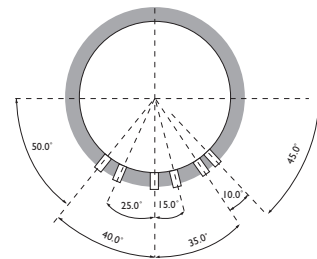
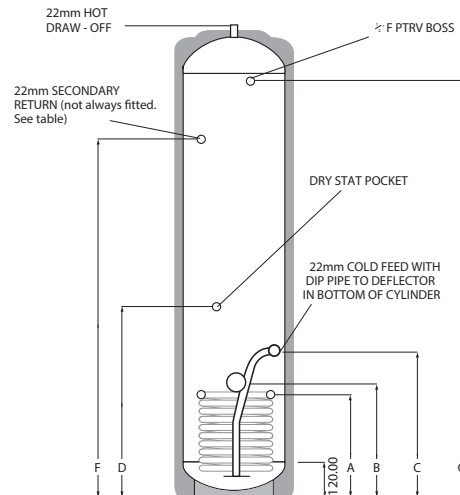

CODE	HEIGHT	DIAMETER	A	B	C	D	F	G	ERP BAND	STANDING LOSS W
NINDSL90L	1048	478	340	380	440	395	N/F	858	B	44
NINDSL120L	1236	478	340	380	440	395	N/F	1046	B	47
NINDSL150L	1424	478	380	420	520	520	N/F	1234	B	54
NINDSL180L	1674	478	380	420	520	610	N/F	1484	B	57
NINDSL210L	1987	478	380	420	520	710	1500	1797	C	66

TECHNICAL SPECIFICATIONS

EHC NEPTUNE DIRECT

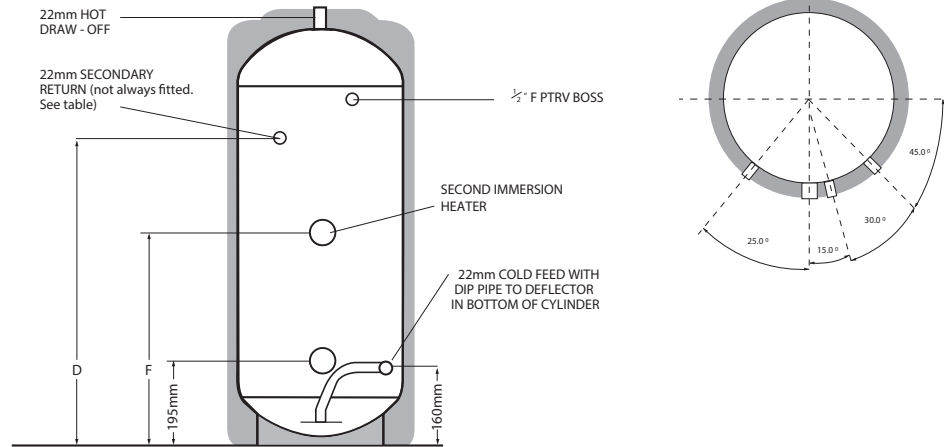

CODE	HEIGHT	DIAMETER	D	F	ERP BAND	Load Profile	kWH/Annum
NDIR120L	906	550	N/F	510	D	M	1461
NDIR150L	1093	550	N/F	610	D	M	1492
NDIR180L	1281	550	N/F	710	D	L	2783
NDIR210L	1469	550	1000	810	D	L	2827
NDIR250L	1719	550	1250	950	D	L	2871
NDIR300L	2032	550	1500	1100	D	XL	4543

EHC NEPTUNE INDIRECT

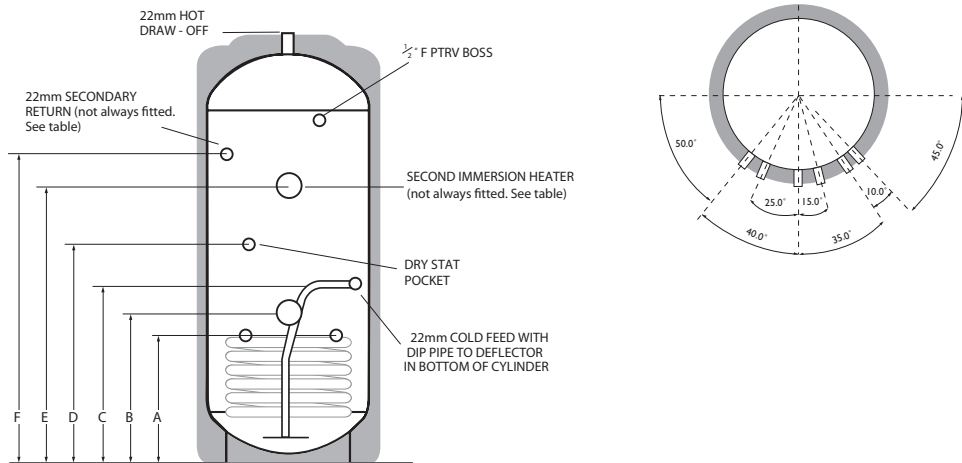

CODE	HEIGHT	DIAMETER	A	B	C	D	E	F	ERP BAND	STANDING LOSS
NIND120L	906	550	290	330	390	345	N/F	N/F	B	44
NIND150L	1093	550	330	370	465	385	N/F	N/F	B	51
NIND180L	1281	550	330	370	465	385	N/F	N/F	B	55
NIND210L	1469	550	365	405	465	465	N/F	1150	C	66
NIND250L	1719	550	365	405	465	560	950	1400	C	77
NIND300L	2032	550	365	405	465	660	1100	1600	C	88

All Dimensions are in mm and are of the cased unit.
N/F = not fitted.



TECHNICAL SPECIFICATIONS

EHC NEPTUNE SOLAR INDIRECT

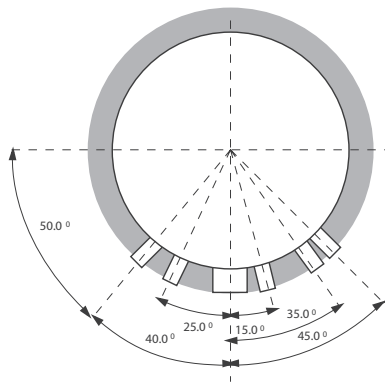
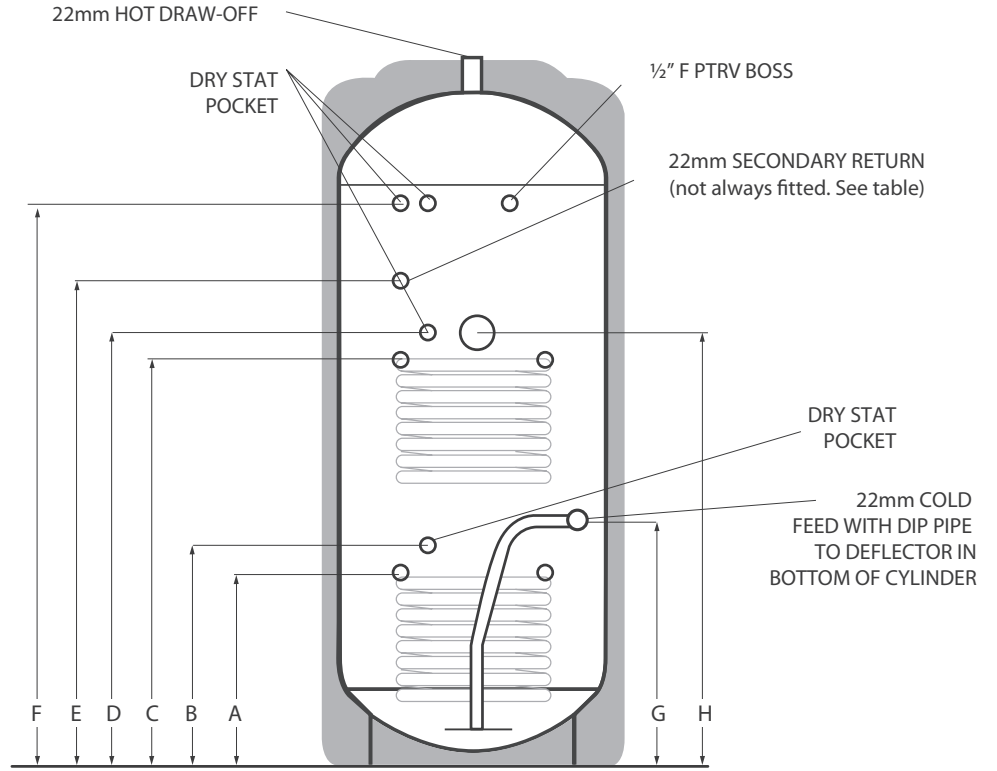

CODE	HEIGHT	DIAMETER	A	B	C	D	E	F	G	H	ERP BAND	STANDING LOSS (W)
NSIND180L	1281	550	290	345	674	729	N/F	1080	390	725	B	55
NSIND210L	1469	550	365	420	779	834	1150	1268	465	830	C	66
NSIND250L	1719	550	365	420	950	1005	1400	1518	465	1000	C	77
NSIND300L	2032	550	365	420	979	1034	1600	1832	465	1030	C	88

All Dimensions are in mm and are of the cased unit.
N/F = not fitted.

EHC NEPTUNE SOLAR INSTALLATION

INDIRECT TWIN COIL CYLINDER

GENERAL

When installing this product it is essential the overall installation meets all current legislation including, in particular, the high limit isolation requirements of Building Regulation G3. This document is designed to assist in achieving that aim.

WATER

The potable water connection and tundish discharge connection are to be connected in exactly the manner described in Pages 5 to 6 of this manual.

UPPER COIL

The upper coil is connected to the fossil fuel boiler as per the instructions for the EHC Neptune Indirect single coil model with the dual stat control and high limit thermostat inserted into pocket D (diagram page 11). The wiring requirements are as depicted on page 12-13.

LOWER COIL: SOLAR INSTALLATION

The flow and return from the solar heat source are to be connected to the indirect coil. Either primary coil connection may be utilised as the flow or return. The solar primary circuit must have its own dedicated circulating pump, thermal and safety controls which must be installed as per the solar manufacturers instructions. The solar control system used must be of the solar differential control type and should be connected to the solar sensor. The solar sensor, supplied as part of the solar controls should be inserts into Pocket B and is held in-situ with the black sensor pocket retaining bung provided. It is necessary to connect the solar pump via the over-temperature high limit cut-out (provided) to ensure the heat input to the solar coil is interrupted if the cylinder overheats. Some method to prevent thermosyphoning must also be employed. Non-return check valves in the primary flow and return pipework would be acceptable. If solar controls do not offer appropriate isolation a 2 port zone valve (not supplied) can be used with the pump and high limit stat as shown to the right.

NOTE: If it is intended to fit a cylinder with a solar coil to be used at a later date, the 2 coils should be connected in series to make use of the solar coil, using the dual stat in Pocket D.

The Domestic Heating Compliance Guide document L1A and L1B provides excellent advice in sizing both cylinder designated solar areas and heat exchangers to the surface area of the solar collectors. Using this guide EHC are able to offer sizing advice for specification.

NB: The total detail of compliance guide document should be consulted prior to specifying product or commencing design.

The schematic wiring diagrams below depict an IMIT high limit control stat and the connections are numbered accordingly. Where an alternative is supplied connect as per manufacturer's instructions.

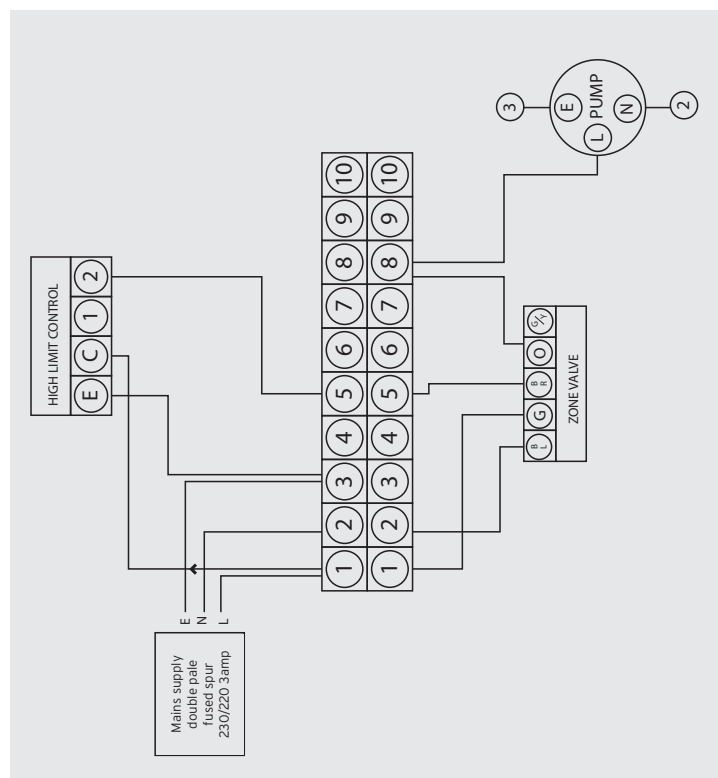
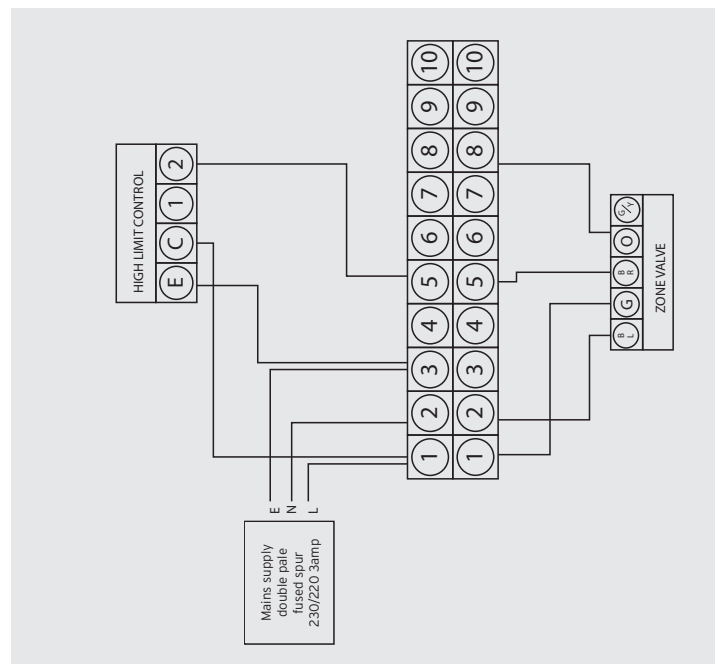

SCHEMATIC WIRING

Heating & Hot Water Wiring: S Plan (Non Standard Volt Free Switching)

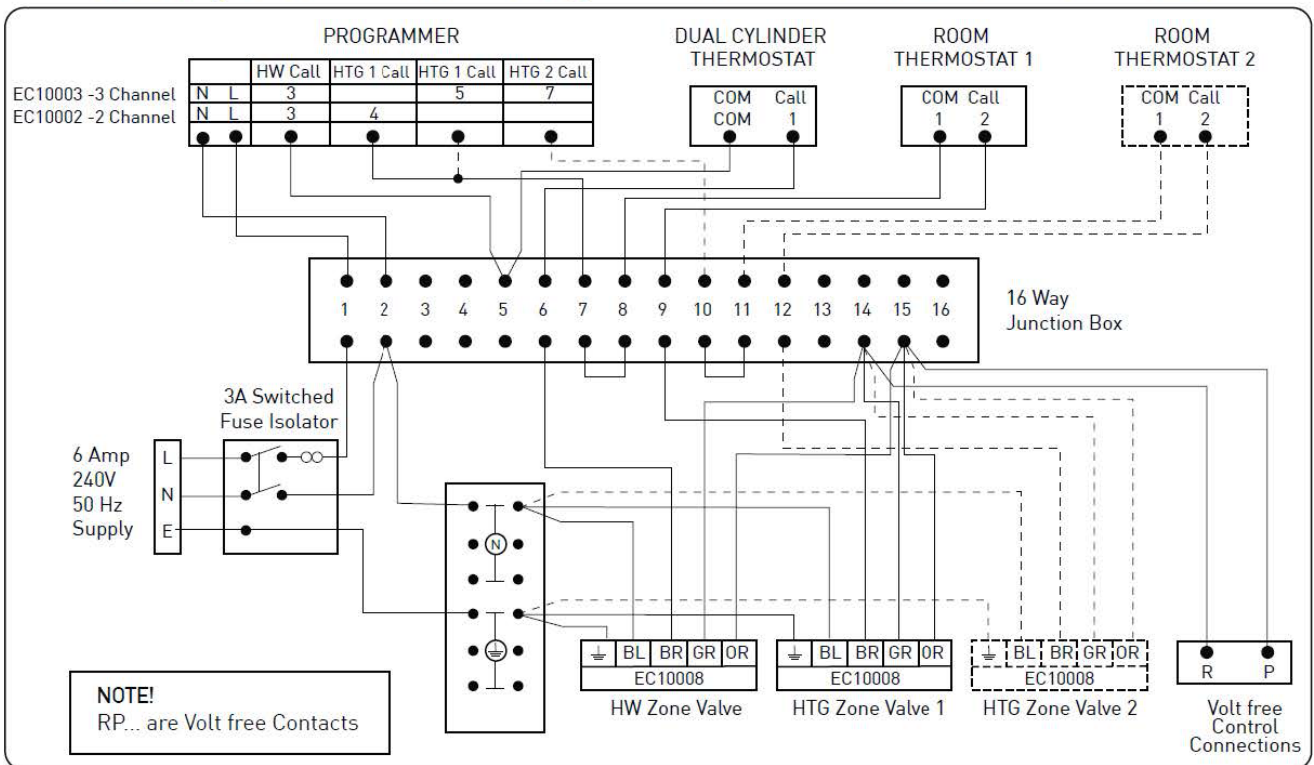

Product: WC3-1
Description: 16 Way junction box

230V~10A 50Hz ClassII -15T55
BS6220 FIXED WIRING MAX 1.5mm

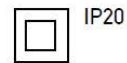

Optional 2nd heating zone



COMMISSIONING

FLUSHING & FILLING

Check that the pressure in the expansion vessel is 3 bar (45PSI), i.e. the same as the setting of the pressure reducing valve. The valve is of the car tyre (Schrader) type. Check all the connections for tightness including any factory made connections such as the immersion heater and the temperature and pressure relief valve. Before filling, open the hot tap furthest away from the EHC Neptune to let air out. Open the cold main isolation valve and allow the unit to fill. When water flows from the tap allow it to run for a short while to flush through any dirt, swarf or flux residue. Close the tap and open every other hot tap in turn to purge all remaining air.

DIRECT UNITS

After filling with water and after sterilisation liquid has been purged, switch on the power to the immersion heaters and allow the unit to start to heat. The immersion heater is supplied preset at 55°C. Turning fully to + sets to approx 65°C. Allow unit to heat up, adjust the thermostat so that the heater switches off at 60°C. Record information on Commissioning Record (Page 19).

INDIRECT UNITS

Consult the boiler manufacturer's commissioning instructions and fill the primary circuit. Ensure the lever on the two port valve is set to the filling position. When full, move the lever back. Switch the programmer to Domestic Hot Water (DHW) and allow the unit to start to heat. Adjust the dial of the dual thermostat to between 55°C and 65°C

as required. Allow unit to heat up, adjust the thermostat so that the heater switches off at 60°C. Record information on Commissioning Record (Page 19).

STORAGE TEMPERATURE

The recommended storage temperature for both direct and indirect cylinders is 60-65°C. In hard water areas consideration should be given to reducing this to 50-55°C. In many healthcare applications the guidance on Legionella control and safe water delivery temperatures will require storing the water at 60-65°C, distributing at 50-55°C and using thermostatic mixing valves to control the final temperature. For details consult the NHS Estates Guidance on safe hot water temperatures.

SAFETY VALVE CHECKS

During heat-up there should have been no sign of water coming from either the expansion relief valve or the temperature/pressure relief valve. Now hold both of these safety valves fully open, allowing as much water as possible to flow through the tundish. Check that your discharge pipework is free from debris and is carrying the water away to waste efficiently. Release the valves and check that they reseal properly. On Completion of commissioning, fill in the Commissioning Record and leave with the house owner.

SERVICING

GENERAL

Servicing should only be carried out by competent installers and any spare parts used must be purchased from the Electric Heating Company. NEVER bypass any safety devices or operate the unit without them being fully operational.

DRAINING

Isolate from the electrical supply to prevent the immersion heaters burning out. Turn off the boiler. Isolate the unit from the cold mains. Attach a hose to the draining tap ensuring that it reaches to a level below the unit (this will ensure an efficient syphon is set up and the maximum amount of water is drained from the unit). First open the hot tap closest to the unit and then open the draining tap.

WARNING: WATER DRAINED OFF MAY BE VERY HOT!

IMPORTANT: After draining the cylinder do not close the hot tap until the cylinder has fully cooled, failure to follow this instruction may result in damage to the cylinder and will invalidate the guarantee.

ANNUAL MAINTENANCE

The EHC Neptune requires an annual service in order to ensure safe working and optimum performance. It is essential that the following checks are performed by a competent

installer on an annual basis. Commonly this is done at the same time as the annual boiler service.

- 1) Twist the cap of the expansion relief valve on the inlet control set and allow water to flow for 5 seconds. Release and make sure it resets correctly. Repeat with the pressure/temperature relief valve. In both cases check that the discharge pipework is carrying the water away adequately. If not, check for blockages etc. and clear.
- 2) Check that any immersion heaters fitted are working correctly and that they are controlling the water at a temperature between 55°C and 65°C.
- 3) Check the pressure in the expansion vessel is charged to 3 bar. Turn off the water supply to the unit and open a hot tap first. The air valve on expansion vessel is a Schrader (car tyre) type. Air or CO² may be used to charge the expansion vessel.
- 4) Unscrew the head on the inlet control set and clean the mesh filter within.
- 5) The service history supplied with this unit should be updated at each service.

YOUR GUARANTEE MAY BE VOID WITHOUT PROOF OF ANNUAL SERVICING.

FAULT FINDING

FAULT	POSSIBLE CAUSE	SOLUTION
Water escaping from the case	Compression fitting on hot - draw off not sealing	Check/remake joint with sealing paste
Cold water at hot taps	Direct - immersion heater not switched on or cutout has triggered	Check / reset
	Indirect - boiler not working	Check boiler - consult boiler manufacturers' instructions
	Indirect - motorised valve fault	Check plumbing / wiring to motorised valve
	Indirect - cutout in dual stat has operated	Reset and investigate cause
Water discharges from expansion relief valve	If continual - pressure reducing valve (part of inlet control set) may not be operating correctly	Check outlet pressure from inlet control set is 3 bar.
	If continual - expansion relief valve seat may be damaged	Remove cartridge - check seat and renew if necessary
	If intermittent - expansion vessel charge may have reduced / bladder perished	Check pressure in expansion vessel. Recharge to 3 bar if necessary. If bladder perished replace vessel.
	Unit is being back pressurised	With cylinder cold check pressure in cylinder. If this is the same as the incoming mains pressure then you are getting backfeed. Install a balanced cold supply (see page 5)
Water discharges from temperature & pressure relief valve	Unit has overheated - thermal controls have failed	Switch off power to boiler and immersion heaters. Leave water supply on. Wait until discharge stops. Isolate water supply and replace if faulty
Milky / cloudy water	Oxygenated water	Water from any pressurised system will release oxygen bubbles when flowing. The bubbles will settle out.
No hot water flow	Cold main off	Check and open stopcock
	Strainer blocked in pressure reducing valve	Isolate water supply and clean
	Inlet control set may be fitted incorrectly	Check and refit as required
Noise during hot water draw-off - typically worse in the morning	Loose airing cupboard pipework	Install extra clips
Hot or warm water from cold tap	If tap runs cold after a minute or so the pipe is picking up heat from heating pipework.	Insulate / re-route

SPARE PARTS

A full range of spare parts is available from Electric Heating Company. Tel: 01698 820533 see page 2 for part numbers.

USER INSTRUCTIONS

Your system is automatic in normal use and requires only annual servicing. You should employ a competent installer to perform the annual servicing. Normally this is timed to coincide with the annual boiler service.

IF WATER IS FLOWING FROM THE SAFETY VALVES THROUGH THE TUNDISH THIS INDICATES A FAULT CONDITION AND ACTION IS NEEDED.

If this water is hot, turn the boiler and / or the immersion heater off. Do not turn off the water until the discharge runs cool. The discharge may also stop.

CALL OUT A COMPETENT PLUMBER TO SERVICE THE

UNIT.

Tell them you have a fault on an unvented cylinder. We stock all the spare parts they may need (see page 2).

DRAINING

IMPORTANT: After draining the cylinder do not close the hot tap until the cylinder has fully cooled; failure to follow this instruction may result in damage to the cylinder and will invalidate the guarantee.

SPECIFICATION

CYLINDER DETAILS & PERFORMANCE

PRODUCT CODE	WEIGHT EMPTY	WEIGHT FULL	CAPACITY	DEDICATED SOLAR VOLUME	FOSSIL FUEL VOLUME	HEAT-UP TIME	70% RE-HEAT TIME	INDIRECT COIL SURFACE AREA	INDIRECT COIL CAPACITY	INDIRECT COIL KW RATING	SOLAR COIL SURFACE AREA	SOLAR COIL CAPACITY	HEAT LOSS (kW/24Hr)
EHC NEPTUNE DIRECT SLIMLINE													
NDIRSL90L	29	120	90	-	-	80m	-	N/A	N/A	N/A	N/A	N/A	1.05
NDIRSL120L	38	160	120	-	-	105m	-	N/A	N/A	N/A	N/A	N/A	1.12
NDIRSL150L	46	200	150	-	-	125m	-	N/A	N/A	N/A	N/A	N/A	1.29
NDIRSL180L	54	235	180	-	-	140m	-	N/A	N/A	N/A	N/A	N/A	1.37
NDIRSL210L	60	270	210	-	-	160m	-	N/A	N/A	N/A	N/A	N/A	1.64
EHC NEPTUNE INDIRECT SLIMLINE													
NINDSL90L	36	130	90	-	-	17m 22s	15m 12s	0.67	3.69	16.1	N/A	N/A	1.05
NINDSL120L	44	165	120	-	-	25m 01s	16m 25s	0.67	3.69	19.0	N/A	N/A	1.12
NINDSL150L	52	205	150	-	-	26m 24s	19m 37s	0.77	4.26	19.5	N/A	N/A	1.29
NINDSL180L	60	240	180	-	-	32m 14s	23m 05s	0.77	4.26	20.4	N/A	N/A	1.37
NINDSL210L	68	280	210	-	-	36m 36s	27m 40s	0.77	4.26	23.4	N/A	N/A	1.64
EHC NEPTUNE DIRECT													
NDIR120L	30	150	120	-	-	110m	-	N/A	N/A	N/A	N/A	N/A	1.05
NDIR150L	35	185	150	-	-	135m	-	N/A	N/A	N/A	N/A	N/A	1.23
NDIR180L	40	220	180	-	-	160m	-	N/A	N/A	N/A	N/A	N/A	1.32
NDIR210L	45	255	210	-	-	185m	-	N/A	N/A	N/A	N/A	N/A	1.58
NDIR250L	50	300	250	-	-	225m	-	N/A	N/A	N/A	N/A	N/A	1.84
NDIR300L	55	355	300	-	-	270m	-	N/A	N/A	N/A	N/A	N/A	2.10
EHC NEPTUNE INDIRECT													
NIND120L	35	155	120	-	-	23m 47s	18m 00s	0.67	3.69	18.35	N/A	N/A	1.05
NIND150L	40	190	150	-	-	29m 36s	20m 35s	0.77	4.26	19.07	N/A	N/A	1.23
NIND180L	45	225	180	-	-	31m 58s	22m 47s	0.77	4.26	20.28	N/A	N/A	1.32
NIND210L	50	260	210	-	-	33m 05s	26m 16s	0.86	4.83	23.08	N/A	N/A	1.58
NIND250L	55	305	250	-	-	41m 18s	28m 20s	0.86	4.83	24.40	N/A	N/A	1.84
NIND300L	60	360	300	-	-	46m 01s	32m 52s	0.86	4.83	24.87	N/A	N/A	2.10
EHC NEPTUNE SOLAR INDIRECT													
NSIND180L	50	235	180	125	55	25m 15s	17m 02s	0.67	3.69	20.2	0.67	3.69	1.32
NSIND210L	55	270	210	145	65	28m 31s	15m 50s	0.77	4.26	23.4	0.86	4.83	1.58
NSIND250L	60	315	250	160	90	31m 42s	22m 42s	0.77	4.26	28.3	0.86	4.83	1.84
NSIND300L	65	370	300	200	100	36m 04s	21m 30s	0.86	4.83	29.2	0.86	4.83	2.10



TECHNICAL SPECIFICATIONS

PRESSURE SPECIFICATIONS

Maximum Inlet Water Pressure	12 Bar
Operating Pressure	3.0 Bar
Expansion Valve Opening Pressure	6.0 Bar
Expansion Vessel Charge Pressure	3.0 Bar
Maximum Operating Pressure	7.0 Bar
Opening Pressure of T & P Valve	7.0 Bar
Opening Temperature of T & P Valve	90°C
Maximum Pressure on Primary Circuit (Indirect & Solar Coil)	3.5 Bar

IMMERSION ELEMENT SPECIFICATIONS

Element Rating	3kW 240 V
Thread Type	1 3/4" BSP
Fuse Requirement	13A via Double Pole Switch
Control Thermostat for Element - Temperature Range	45°C - 65°C
High Limit Thermostat for Element - Temperature Set Point	85°C



COMMISSIONING RECORD

Commissioning Date.....	Engineer's Name.....
Customer Name.....	Company Name.....
Customer Phone Number	Company Address
Cylinder Model Number	Telephone Number.....
Cylinder Serial Number	Registered Operator ID Number,.....
	Building Regulation Notification Number (if applicable)

PRIMARY INDIRECT SYSTEM INFORMATION

Primary circuit SEALED OPEN VENTED

Primary circuit flow temperature

Primary circuit expansion vessel size required

Primary circuit expansion vessel pre-charge

Primary flow temperature

Where is the Pressure Reducing Valve fitted?
.....

What is the PRV setting?.....

Has the Expansion Relief Valve been tested?

Has the T & P valve been tested?

Does the discharge pipework meet building regulations?
.....

POTABLE WATER INFORMATION

What is the standing pressure at the cylinder?

What is the dynamic pressure at the cylinder?

What is the pre-charge in the potable vessel?

Does the discharge pipework carry discharge away in a safe manor?

Have all safety features been checked?

DOES THE INSTALLATION COMPLY WITH THE APPROPRIATE BUILDING REGULATIONS?	YES	NO
HAS THE SYSTEM BEEN COMMISSIONED IN LINE WITH INSTRUCTIONS?	YES	NO
HAS THE PRIMARY CIRCUIT BEEN DOSED WITH INHIBITOR? N/A	YES	NO
HAVE THE CORRECT CONTROLS BEEN INSTALLED?	YES	NO
HAS THE SYSTEM BEEN FULLY EXPLAINED TO THE CUSTOMER?	YES	NO

COMMISSIONING ENGINEER SIGNATURE.....

CUSTOMER SIGNATUREDATE



SERVICE HISTORY

SERVICE 1 Date.....

Engineer's Name.....

Company Name.....

Telephone Number.....

Pressure in Potable Expansion Vessel.....

Safety valves functioning YES NO

Actions

Discharge pipe clear YES NO

Actions.....

Temperature of hot water.....

Immersion heater connected YES NO N/A

Actions

Signature.....

SERVICE 2 Date.....

Engineer's Name.....

Company Name.....

Telephone Number.....

Pressure in Potable Expansion Vessel.....

Safety valves functioning YES NO

Actions

Discharge pipe clear YES NO

Actions.....

Temperature of hot water.....

Immersion heater connected YES NO N/A

Actions

Signature.....

SERVICE 3 Date.....

Engineer's Name.....

Company Name.....

Telephone Number.....

Pressure in Potable Expansion Vessel.....

Safety valves functioning YES NO

Actions

Discharge pipe clear YES NO

Actions.....

Temperature of hot water.....

Immersion heater connected YES NO N/A

Actions

Signature.....

SERVICE 4 Date.....

Engineer's Name.....

Company Name.....

Telephone Number.....

Pressure in Potable Expansion Vessel.....

Safety valves functioning YES NO

Actions

Discharge pipe clear YES NO

Actions.....

Temperature of hot water.....

Immersion heater connected YES NO N/A

Actions

Signature.....



SERVICE HISTORY CONT.

SERVICE 5 Date.....

Engineer's Name.....

Company Name.....

Telephone Number.....

Pressure in Potable Expansion Vessel.....

Safety valves functioning YES NO

Actions

Discharge pipe clear YES NO

Actions.....

Temperature of hot water.....

Immersion heater connected YES NO N/A

Actions

Signature.....

SERVICE 6 Date.....

Engineer's Name.....

Company Name.....

Telephone Number.....

Pressure in Potable Expansion Vessel.....

Safety valves functioning YES NO

Actions

Discharge pipe clear YES NO

Actions.....

Temperature of hot water.....

Immersion heater connected YES NO N/A

Actions

Signature.....

SERVICE 7 Date.....

Engineer's Name.....

Company Name.....

Telephone Number.....

Pressure in Potable Expansion Vessel.....

Safety valves functioning YES NO

Actions

Discharge pipe clear YES NO

Actions.....

Temperature of hot water.....

Immersion heater connected YES NO N/A

Actions

Signature.....

SERVICE 8 Date.....

Engineer's Name.....

Company Name.....

Telephone Number.....

Pressure in Potable Expansion Vessel.....

Safety valves functioning YES NO

Actions

Discharge pipe clear YES NO

Actions.....

Temperature of hot water.....

Immersion heater connected YES NO N/A

Actions

Signature.....



SERVICE HISTORY CONT.

SERVICE 9 Date.....

Engineer's Name.....

Company Name.....

Telephone Number.....

Pressure in Potable Expansion Vessel.....

Safety valves functioning YES NO

Actions

Discharge pipe clear YES NO

Actions.....

Temperature of hot water.....

Immersion heater connected YES NO N/A

Actions

Signature.....

SERVICE 10 Date.....

Engineer's Name.....

Company Name.....

Telephone Number.....

Pressure in Potable Expansion Vessel.....

Safety valves functioning YES NO

Actions

Discharge pipe clear YES NO

Actions.....

Temperature of hot water.....

Immersion heater connected YES NO N/A

Actions

Signature.....

SERVICE 11 Date.....

Engineer's Name.....

Company Name.....

Telephone Number.....

Pressure in Potable Expansion Vessel.....

Safety valves functioning YES NO

Actions

Discharge pipe clear YES NO

Actions.....

Temperature of hot water.....

Immersion heater connected YES NO N/A

Actions

Signature.....

SERVICE 12 Date.....

Engineer's Name.....

Company Name.....

Telephone Number.....

Pressure in Potable Expansion Vessel.....

Safety valves functioning YES NO

Actions

Discharge pipe clear YES NO

Actions.....

Temperature of hot water.....

Immersion heater connected YES NO N/A

Actions

Signature.....



SERVICE HISTORY CONT.

SERVICE 13 Date.....

Engineer's Name.....

Company Name.....

Telephone Number.....

Pressure in Potable Expansion Vessel.....

Safety valves functioning YES NO

Actions

Discharge pipe clear YES NO

Actions.....

Temperature of hot water.....

Immersion heater connected YES NO N/A

Actions

Signature.....

SERVICE 14 Date.....

Engineer's Name.....

Company Name.....

Telephone Number.....

Pressure in Potable Expansion Vessel.....

Safety valves functioning YES NO

Actions

Discharge pipe clear YES NO

Actions.....

Temperature of hot water.....

Immersion heater connected YES NO N/A

Actions

Signature.....

SERVICE 15 Date.....

Engineer's Name.....

Company Name.....

Telephone Number.....

Pressure in Potable Expansion Vessel.....

Safety valves functioning YES NO

Actions

Discharge pipe clear YES NO

Actions.....

Temperature of hot water.....

Immersion heater connected YES NO N/A

Actions

Signature.....

SERVICE 16 Date.....

Engineer's Name.....

Company Name.....

Telephone Number.....

Pressure in Potable Expansion Vessel.....

Safety valves functioning YES NO

Actions

Discharge pipe clear YES NO

Actions.....

Temperature of hot water.....

Immersion heater connected YES NO N/A

Actions

Signature.....



SERVICE HISTORY CONT.

SERVICE 17 Date.....

Engineer's Name.....

Company Name.....

Telephone Number.....

Pressure in Potable Expansion Vessel.....

Safety valves functioning YES NO

Actions

Discharge pipe clear YES NO

Actions.....

Temperature of hot water.....

Immersion heater connected YES NO N/A

Actions

Signature.....

SERVICE 18 Date.....

Engineer's Name.....

Company Name.....

Telephone Number.....

Pressure in Potable Expansion Vessel.....

Safety valves functioning YES NO

Actions

Discharge pipe clear YES NO

Actions.....

Temperature of hot water.....

Immersion heater connected YES NO N/A

Actions

Signature.....

SERVICE 19 Date.....

Engineer's Name.....

Company Name.....

Telephone Number.....

Pressure in Potable Expansion Vessel.....

Safety valves functioning YES NO

Actions

Discharge pipe clear YES NO

Actions.....

Temperature of hot water.....

Immersion heater connected YES NO N/A

Actions

Signature.....

SERVICE 20 Date.....

Engineer's Name.....

Company Name.....

Telephone Number.....

Pressure in Potable Expansion Vessel.....

Safety valves functioning YES NO

Actions

Discharge pipe clear YES NO

Actions.....

Temperature of hot water.....

Immersion heater connected YES NO N/A

Actions

Signature.....



SERVICE HISTORY CONT.

SERVICE 21 Date.....

Engineer's Name.....

Company Name.....

Telephone Number.....

Pressure in Potable Expansion Vessel.....

Safety valves functioning YES NO

Actions

Discharge pipe clear YES NO

Actions.....

Temperature of hot water.....

Immersion heater connected YES NO N/A

Actions

Signature.....

SERVICE 22 Date.....

Engineer's Name.....

Company Name.....

Telephone Number.....

Pressure in Potable Expansion Vessel.....

Safety valves functioning YES NO

Actions

Discharge pipe clear YES NO

Actions.....

Temperature of hot water.....

Immersion heater connected YES NO N/A

Actions

Signature.....

SERVICE 23 Date.....

Engineer's Name.....

Company Name.....

Telephone Number.....

Pressure in Potable Expansion Vessel.....

Safety valves functioning YES NO

Actions

Discharge pipe clear YES NO

Actions.....

Temperature of hot water.....

Immersion heater connected YES NO N/A

Actions

Signature.....

SERVICE 24 Date.....

Engineer's Name.....

Company Name.....

Telephone Number.....

Pressure in Potable Expansion Vessel.....

Safety valves functioning YES NO

Actions

Discharge pipe clear YES NO

Actions.....

Temperature of hot water.....

Immersion heater connected YES NO N/A

Actions

Signature.....

GUARANTEE TERMS AND CONDITIONS

This guarantee applies only to the product named EHC Neptune Unvented Hot Water Cylinder. Hereafter the term 'product' refers to EHC Neptune Hot Water Cylinder.

Electric Heating Company guarantees to the homeowner that for a period of 2 years from the date of commissioning or legal completion if new build, that the products and associated components installed will conform to EHC specification; and be free from defects in materials and workmanship, subject to the conditions set out below.

Please note: this guarantee excludes all pipework and connections and excludes any ancillary equipment as may be connected to the product. (Ex: descaling equipment, water softeners)

The guarantee is extended to a total of 25 years for the stainless steel inner vessel in domestic properties.

This guarantee means that Electric Heating Company will take responsibility for the cost of guarantee repair of a product by an approved Electric Heating Company Service Engineer, so that the product shall conform to Electric Heating Company specification.

Electric Heating Company reserves the right, at its discretion to replace a product or major component where it considers it to be beyond economical repair.

In the event of a breakdown during the guarantee period please call our Customer Service Department on:

01698 820533

Guarantee repair is free of charge to you for any parts and labour, providing all the guarantee conditions have been met.

GUARANTEE TERMS & CONDITIONS

Please read the following conditions before registering your product and before seeking any guarantee service support
IMPORTANT: Electric Heating Company guarantee is subject to the homeowner registering with the Electric Heating Company Customer Service Department within 30 days of commissioning / occupation if new build to confirm:

- Product Make / Model
- Details of installation

Please complete the registration card provided and return to:

Customer Service Department, Electric Heating Company, Unit 40 Block 5 Third Road Blantyre Glasgow G72 0UP or register the product on-line at www.electric-heatingcompany.co.uk/warranty-registration/
If you do not register the Product then Electric Heating Company Guarantee is limited to twelve months from the date of commissioning.

The product must be maintained by a competent person* within 12 months after commissioning, and thereafter at 12 monthly intervals. Electric Heating Company reserves the right to seek evidence of this maintenance to our reasonable satisfaction before approving any guarantee servicing / repairs. This may include evidence of completed Service

Record and service agreement / invoice.

Annual Services are available from the Customer Service/ Technical Support team.

*A competent person is a business that has been adjudged by an accredited body** to be sufficiently competent to self-certify that its work complies with Document (G) Part 3 of the Building Regulations of England and Wales

*May Include SEI registered installers and/or FAS trained plumbers who have completed the renewables technology module

** An example of which is BPEC

Any exchanged component will become the legal property of Electric Heating Company.

This guarantee is valid provided that:

- The product has been installed by a competent installer and as per the instructions contained in the installation manual and all relevant Codes of Practice and Regulations in force at the time of installation.
- Any disinfection has been carried out in accordance with BS 6700.
- The product has not been modified in any way.
- The system is fed from domestic mains water supply and is in compliance with water regulations 1999, the water supply(Scotland) byelaws 2014, water supply regulations(Northern Ireland) 2009 or the water services act(Ireland) 2007
- The product has only been used for the storage of wholesome water (max. 250mg/l chloride - for hard water areas, EHC recommend the use of an electrolytic scale reducer)
- Any 3rd party labour charges associated with replacing the unit or any of its components have been authorised in advance by the Customer Service/ Technical Support team.
- It has only been used for the storage of potable water.
- The product has not been subjected to frost, nor has it been tampered with or been subjected to misuse or neglect.
- No factory fitted parts have been removed for unauthorised repair or replacement.
- The Benchmark™ Commissioning Checklist and Service Record included with this product Installation Manual have been completed.
- Regular maintenance has been carried out by a competent person in accordance with the requirements set out in the maintenance section of the installation manual.
- The owner or installer has registered the product on-line at www.electric-heatingcompany.co.uk/warranty-registration within 30 days of purchase or by sending completed Guarantee slip (page 27).
Failure to do so may result in a reduced warranty period.
- Evidence of purchase and date of supply must be submitted upon making a claim.
- Any replacement parts used should be authorised Electric Heating Company spare parts.

GUARANTEE TERMS AND CONDITIONS

• If a defect arises and a valid claim is received within the warranty period, at its option and to the extent permitted by law the Electric Heating Company shall either

(1) Repair the defect at no charge, using new or refurbished replacement parts

or

(2) Exchange the product with a product that is new or which has been manufactured using new or serviceable used parts

or

(3) Refund the purchase price or a reasonable proportion of the purchase price.

The Electric Heating Company reserves the right to inspect the product at your home before proceeding with any guarantee repair or replacement.

Any valid guarantee claim or guarantee service does not extend the original guarantee period. Information on extend warranties is available upon request.

The guarantee only applies to the property at which the product was originally installed and applied only to properties in the United Kingdom & Ireland. The guarantee is fully transferable from a change of legal ownership of the property.

EXCLUSIONS - The guarantee does not cover:

Electric Heating Company will not be liable for any fault or costs arising from incorrect installation, incorrect application, lack of regular maintenance or neglect, accidental damage, malicious damage, misuse, any alteration, tampering or repair carried by a non competent person.

• The product if the factory fitted temperature and pressure relief valve has been tampered with or removed.

• Neither the Distributor nor Manufacturer shall be responsible for any consequential damage howsoever

caused.

• The effects of scale build up or the effects of corrosion.

• Any consequential losses caused by the failure or malfunction of the product.

• Faults and any associated costs arising from lack of power or water.

• Failure incurred by water contamination, air pollution and natural disasters.

• This guarantee is not valid for installations outside the United Kingdom and Ireland.

• Any consequential loss, loss of profits, revenues or receipts howsoever arising from any non-conformity or defect affecting the product or from any delay in repair or replacement of the product.

• Any loss or damage caused by delay in conduct of services or supply of parts required to rectify the non-conformity or defect (provided Electric Heating Company will use all reasonable efforts to ensure services are performed on a timely basis).

• For repair or replacement of any product consumables or decorative finishes, such as filters and casings.

This guarantee does not affect any legal rights you may have as a consumer under applicable national legislation governing your purchase of this product

For installations outside of the United Kingdom and Ireland, please contact Customer Service/ Technical Support.

The Electric Heating Company shall make final determination as to the validity of any guarantee claim, and shall be entitled to charge you all reasonable costs incurred in investigating the claim where there is no fault found, or the guarantee claim is rejected in accordance with these conditions.



Customer Service Department
The Electric Heating Company Ltd
Unit 40 Block 5 Third Road
Blantyre Industrial Estate
Blantyre Glasgow
G72 0UP



GUARANTEE REGISTRATION CARD

To be completed by the home owner. Please use this card to register within 30 days of commissioning / occupation if new build to benefit from the Electric Heating Company 25 year guarantee.

By completing this form, you consent to Electric Heating Company holding and using those details for all purposes directly related to the administration and conduct of guarantee services. Apart from the necessary usage, your personal data will not be disclosed to third parties by Electric Heating Company.



Home Owner Name

Home Address

Post code

Make of product

Model/size

Serial Number

Installers Contact details
(can be found in benchmark log book)

Date of installation
(can be found in benchmark log book)

Signature of homeowner

Date

Or Signature of developer
(If new build)

Date