

SANTON

Installation and User Instructions Aquarius Undersink Vented Water Heaters Models: AU7/3, AU7/1, AU10/3, AU10/1.

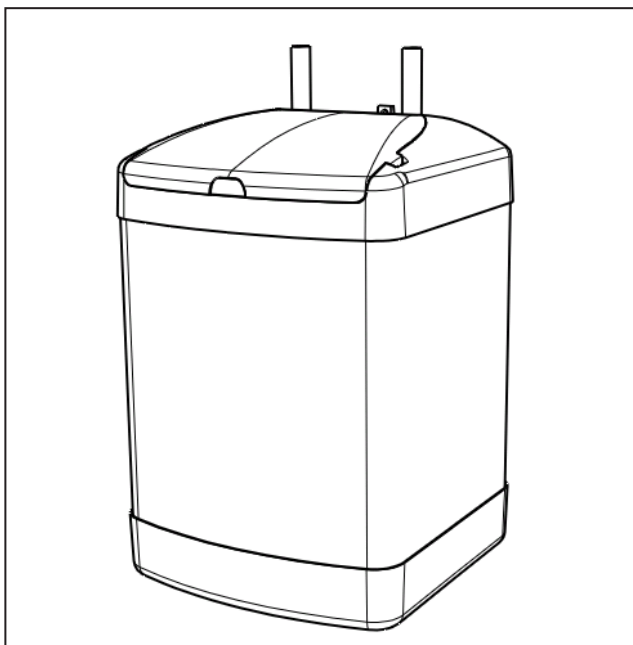

Please read and understand these instructions before starting work.
Please leave this leaflet with the user following installation

PACK CONTENTS

Heater, Fixing screws and plugs,
Installation and User Instructions, and
Guarantee card.

WARNING

This water heater must only be installed by
competent persons

1.0 INTRODUCTION

Thankyou for purchasing a Santon Aquarius water heater. The Aquarius water heater is manufactured in the UK to the highest standards and has been designed to meet all the latest relevant safety specifications.

This Aquarius water heater must be installed and maintained by a competent person only. Please read and understand these instructions prior to installing your Aquarius water heater. Particular attention should be paid to section three headed INSTALLATION. Following installation the operation of the heater should be explained to the user and these instructions left with them for future reference.

This appliance can be used by children aged from 8 years and above and persons with reduced physical sensory or mental capabilities or lack of experience and knowledge if they have been given supervision or instruction concerning use of the appliance in a safe way and understand the hazards involved. Children shall not play with the appliance. Cleaning and user maintenance shall not be made by children without supervision.

Children must be supervised to ensure they do not play with the appliance.

2.0 TECHNICAL SPECIFICATION

Electrical rating	1.17/1.2kW@230/240V~ 2.75/3.0kW@230/240V~
Capacities	7 & 10 litres
Weight	7 litre - 9.3kg, 10 litre - 12.5kg
Rated Pressure.....	0Mpa (0bar)
Minimum recommended supply pressure	Mains fed or cistern fed (3m head required)
Maximum supply pressure	0.2 Mpa (2bar) (15m head max)
Temperature range	10 to 70°C

Name	Aquarius			
Model	AU7/3	AU7/1	A10U/3	A10U/1
Volume Litres	7	7	10	10
V40	10	10	13	13
Load Profile	XXS	XXS	XXS	XXS
Energy Efficiency Class	B	B	B	B
Energy Efficiency %	33.1	33.1	33.1	33.1
Annual electricity consumption kWh	558	558	556	556
Daily fuel consumption kWh	2.670	2.670	2.660	2.660
Thermostat setting	60°C			
Specific precautions that shall be taken when the water heater is assembled, installed or maintained and disposed of at end of life	See Section 2 to 5			

Table: Technical parameters in accordance with European Commission regulations 814/2013 and 812/2013

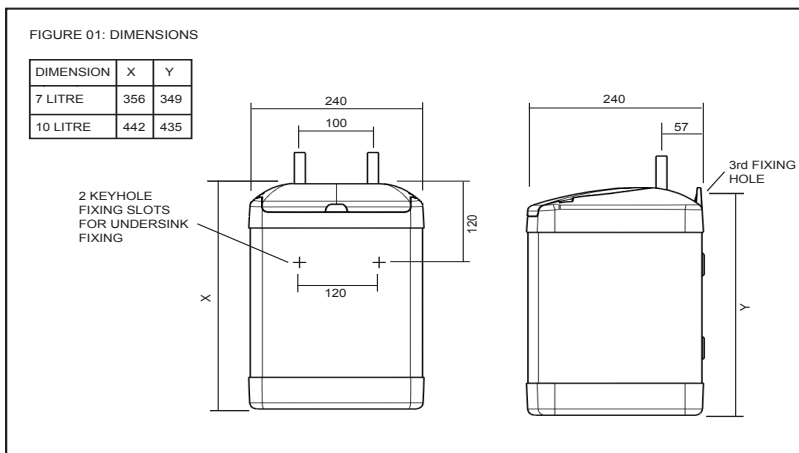

3.0 INSTALLATION

3.1 LOCATION

- 3.1.1 Inlet must always be on the right.
- 3.1.2 The outlet of this water heater acts as a vent and must not be blocked or restricted in any way.
- 3.1.3 Only Santon open outlet accessories must be used with this water heater. A full range is available, please consult your distributor or Santon for further information.
- 3.1.4 The installation must be carried out in accordance with the relevant requirements of the appropriate Building Regulations, either:
 - The Building Regulations
 - The Building Regulations (Scotland) or Building Regulations (N Ireland)

The Water Fittings Regulations or water Byelaws in Scotland

- 3.1.5 Select a suitable site but check that:
 - a) There is enough clearance above the heater to allow for pipe connections and removal of the element plate.
 - b) There are no hidden services where the wall is to be drilled.
 - c) Maximum outlet pipe run to tap 1 M, outlet and vent should rise continually
- 3.1.6 Mark the position of the fixing holes (as shown in Figure 01).
- 3.1.7 Drill and plug the hole positions.
- 3.1.8 Screw in the lower two screws leaving heads 3mm from the wall.
- 3.1.9 Hang the heater on the two screws.
- 3.1.10 Screw in top screw to secure heater.
- 3.2 PLUMBING
 - 3.2.1 This water heater is designed for cistern-fed application in conjunction with a separate cistern and vent pipe (see Figure 02) Max 15M head
 - 3.2.2 Alternatively the heater can be connected directly to the water mains provided that a Santon 'vented tap' is used (see Figure 03) Max 2Bar mains water pressure , or a 2 Bar pressure reducing valve must be fitted.
 - 3.2.3 Both inlet and outlet pipes are clearly labelled. The pipes are 15mm tube and are suitable for compression fittings.
 - 3.2.4 It is recommended that a WRAS listed isolating valve (not supplied) be fitted in the water supply pipe to the heater to allow for servicing.
- 3.3 ELECTRICAL
 - 3.3.1 Warning: this appliance must be earthed. It is suitable for a.c. supply only. Electrical installation must be carried out by a competent electrician and be in accordance with the latest I.E.E. regulations.
 - 3.3.2 Nominal cross-section of supply cable must be at least 1.5mm². A double pole isolating switch with a contact separation of at least 3mm in each pole must be incorporated in the supply.
 - 3.3.3 Remove the terminal cover using a large flat bladed screwdriver to relieve the snaps located towards the front at either side of the cover. Gripping the cover at the front, pull upwards.
 - 3.3.4 Strip the outer sheath and insulation on the cable to the required lengths, push the cable through the grommet provided, this will be held in the cable grip when the connections are made (see Figure 04).
 - 3.3.5 Pass the cable underneath the cable grip and through the top moulding.
 - 3.3.6 Make the connections to the terminal block as follows:
 - Live (brown or red wire) to terminal marked "L"
 - Neutral (blue or black wire) to terminal marked "N"
 - Earth (green or green/yellow wire) to terminal marked 
 - 3.3.7 Secure the cable in the cable grip by tightening the two screws.
 - 3.3.8 Set the adjustable thermostat by rotating the control to the required temperature. It is recommended that it is set to lowest acceptable temperature to meet user requirements. This will minimise the risk of scalding and reduce the level of scaling in hard water areas.
 - 3.3.9 Replace terminal cover by locating the hinge at the rear. Slide the snaps into place. Apply pressure to the front of the cover, pushing back and down until it snaps securely in place.

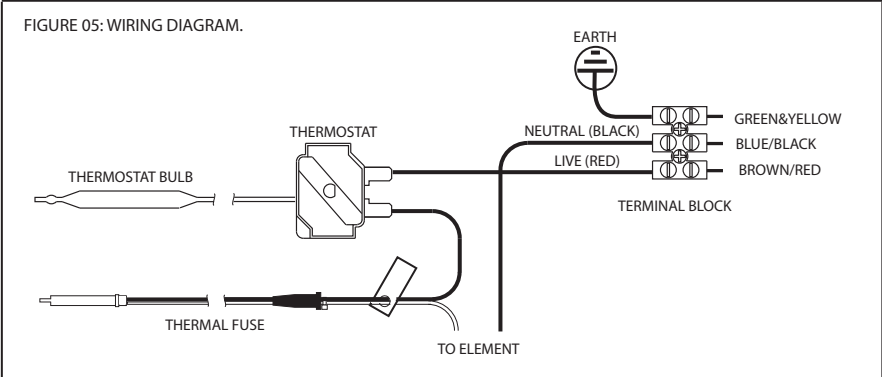
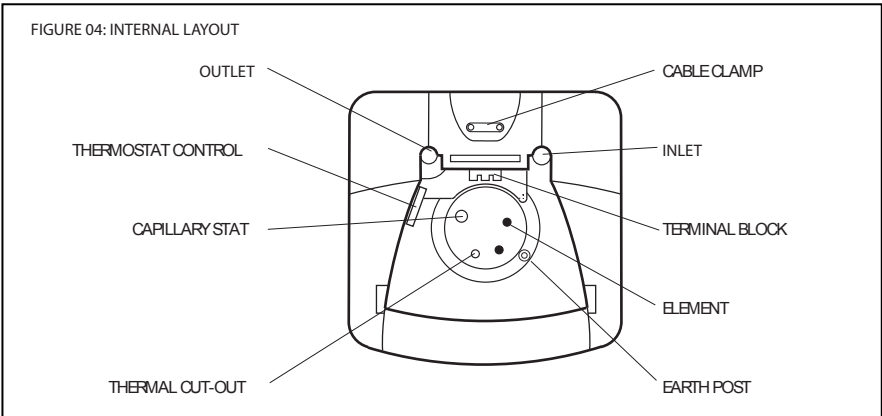
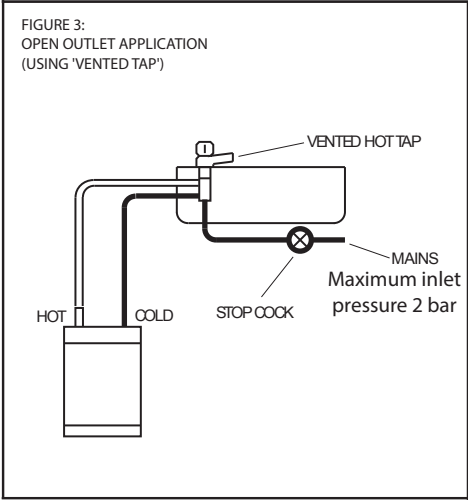
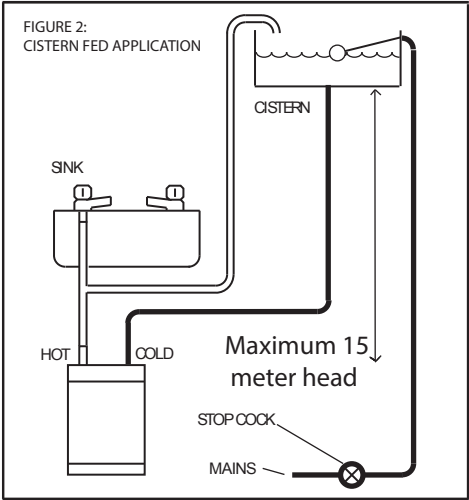

4.0 COMMISSIONING

- 4.1 DO NOT SWITCH ON HEATER UNTIL IT IS FILLED WITH WATER
Fill with water by opening tap and leaving open until a full bore of water flows from the outlet.
- 4.2 Switch on water heater at double pole isolating switch. The heater will heat water to the temperature set on the thermostat.
- 4.3 Check water is heating correctly.
7 litre 1.2kW - after 10 mins water temperature will increase by 20°C
7 litre 3kW - after 10 mins water temperature will increase by 60°C
10 litre 1.2kW - after 10 mins water temperature will increase by 15°C
10 litre 3kW - after 10 mins water temperature will increase by 40°C
- 4.4 Pass instruction leaflet to user and draw their attention to the following two statements:

DO NOT USE HEATER IF THE WATER IS THOUGHT TO BE FROZEN

Switch off immediately at the isolating switch if the water does not flow freely.

Any damage resulting from freezing will not be covered by the guarantee.

DURING HEATING THE OUTLET WILL DRIP

This is due to the expansion of water inside the heater and is normal for heaters of this type. It does not indicate that the valve is faulty and over tightening of the valve can result in damage.

5.0 FAULT FINDING

Your Aquarius water heater should give you trouble free operation, however, should a problem occur the table below should enable most faults to be identified with ease.

For any faults that cannot be identified using the fault finding table, please contact Santon Service Department on 0344 871 1530

Fault finding should only be carried out by a competent person and any replacement part should be authorised Santon spare parts.

SYMPTOM	PROBABLE CAUSE	ACTION
No hot water	1. Check power	Check and replace as necessary.
	2. Faulty cut out	
	3. Faulty thermostat	
	4. Faulty element	
Water too hot /cold	1. Thermostat set to wrong temperature	Adjust thermostat.
	2. Faulty thermostat	Switch off, check and replace.
No water flow	1. Frozen	Switch off electrical power and allow to thaw at room temperature. Do not switch on again until full water flow restored and full checks made for leaks and electrical safety.
	2. No mains supply	Check mains.
Continuous water flow	Faulty valve/tap	Check and replace.

6.0 SPARE PARTS

In the unlikely event of your Water Heater developing a fault, the following spare parts are available:

Element plate assembly 7 litre 1.2kW	95 606 902
Element plate assembly 7 litre 3kW	95 606 903
Element plate assembly 10 litre 1.2kW	95 606 904
Element plate assembly 10 litre 3kW	95 606 905
Element plate assembly gasket	95 611 021
Capillary thermostat	95 612 051
Over temperature cut-out	95 612 050
Top cover moulding	95 614 272
Terminal cover	95 614 273
Adaptor long	95 607 954
Adaptor o-ring	95 607 955
Retaining Clip	95 607 956

7.0 GUARANTEE

This product is guaranteed against faulty materials and manufacture for a period of 2 years from the date of purchase provided that:

1. The unit has been installed in accordance with the Installation and User Instructions and all relevant Codes of Practice and Regulations in force at the time of Installation, and that all necessary controls and safety valves have been fitted correctly.
2. Any valves and controls are of the Santon recommended type and specification.
3. The unit has not been modified or tampered with in any way, and has been regularly maintained as detailed in the Installation and User Instructions.
4. The unit has been used only for heating potable water.

The unit is not guaranteed against damage by frost, and the inner container with integral immersion heater is not guaranteed against excessive scale build-up.

This Guarantee in no way affects the statutory rights of the consumer.

Santon's policy is one of continuous product development and, as such, we reserve the right to change specifications without notice.

8.0 ENVIRONMENTAL INFORMATION

This product is manufactured from many recyclable materials.

At the end of its useful life it should be disposed of at a Local Authority Recycling Centre in order to realise the full environmental benefits. Insulation is by means of CFC-free polyurethane foam.

This product does not contain any substances harmful to health; it does not contain any asbestos.

WEEE Declaration

Disposal of Waste Equipment by Users in Private Households in the European Union.



This symbol on the product indicates that this product must not be disposed of with your other household waste. Instead, it is your responsibility to dispose of your waste equipment by handing it over to a designated collection point for the recycling of waste electrical equipment. The separate collection and recycling of your waste equipment at the time of disposal will help to conserve natural resources and ensure that it is recycled in a manner that protects human health and the environment. For more information about where you can drop off your waste equipment for recycling, please contact your local city office, your household waste disposal service or the company where this product was purchased.

9.0 SPARES STOCKISTS

Parts Center
Tel: 0344 292 7057
www.partscenter.co.uk

Newey & Eyre
Unit 3 - 5 Wassage Way
Hampton Lovett Ind. Estate,
Droitwich, Worcestershire WR9 0NX
Tel : 01905 791500
Fax: 01905 791501

UK Spares Ltd.
Unit 1155 Aztec West,
Almondsbury,
Bristol BS32 4TF
Tel: 01454 620500

Electric Water Heating Co.
2 Horsecroft Place, Pinnacles,
Harlow, Essex CM19 5BT
E-mail: sales@ewh.co.uk

SPD
Units 9 & 10 Hexagon Business Centre
Springfield Road, Hayes
Middlesex UB4 0TY
Tel : 020 8606 3567

Alternatively, contact your local supplying merchant, wholesale branch or use our online stockist finder at www.interpartspares.co.uk

SANTON

BY HEATRAESADIA

Hurricane Way,
Norwich
Norfolk, NR6 6EA.
www.santon.co.uk

Service Tel: 0344 871 1530
Service E-mail:
customer.support@heatraesadia.com