



ZIP InLine

Electronic Instantaneous
Water Heaters

Models: ES3, ES4 & ES6



Contents

Description	3
Approvals	3
Safety information	4
WARNING 	4
CAUTION 	5
Dimensions	5
Technical data	6
Spare Parts	7
Installation	8
Requirements	8
Installation site	8
Installing the appliance	9
Plumbing connection	10
Electrical connection / wiring diagram	12
Commissioning	12
Operation / Temperature & flow adjustment	13 - 14
Maintenance and cleaning	14 - 15
Fault finding	16
Warranty	17

IMPORTANT:

PLEASE READ THESE INSTRUCTIONS CAREFULLY.

NOTE THE SAFE OPERATIONAL REQUIREMENTS, WARNINGS AND CAUTIONS. USE THIS PRODUCT CORRECTLY AND WITH CARE FOR THE PURPOSE FOR WHICH IT IS INTENDED. FAILURE TO DO SO MAY CAUSE DAMAGE AND/OR PERSONAL INJURY, AND WILL INVALIDATE THE WARRANTY. RETAIN THESE INSTRUCTIONS FOR FUTURE USE.

Please leave these instructions with the end user after installation.

To ensure you have the latest revision of this instruction manual, please visit www.zipheaters.co.uk to download the latest copy.

In order to preserve our environment we ask that you dispose of this product correctly. Please contact Zip Customer Service for advice on 0845 6 005 005 or 0345 6 005 005

Description

Zip InLine ES3, ES4 and ES6 instantaneous water heaters are compact electronically controlled instantaneous water heaters for hand washing.

This small instantaneous water heater is intended to provide economical heating of water for a wash basin when installed together with a sanitary water fitting. When the hot-water tap is opened, the heater switches itself on automatically when the minimum water flow rate is exceeded and heats the water as it passes through the appliance.

The heater is pre-set in the factory to an outlet temperature of about 38°C, which is ideal for hand washing. When this temperature is reached, the electronic regulator reduces the power in order to ensure that the outlet temperature does not exceed this value. This automatic temperature regulation means that it is only necessary to open the hot water tap to obtain water at a constant, safe temperature for washing hands. If the set outlet temperature is not reached, slightly reduce the flow of water from the tap. Cold water may be added if a lower temperature is required.

If the flow rate is too low or if the hot water tap is closed, the appliance switches itself off automatically. For an optimum flow of water, always fit the special jet regulator supplied with the appliance. This regulator should be inserted into the threaded retainer on the tap outlet.

The maximum possible outlet temperature is determined by the temperature of the incoming water, the flow rate and the heating power of the heater.

The temperature set point and flow rate can be preset inside the appliance to achieve an outlet temperature between about 30°C and 43°C.

Power consumption is also regulated based on outlet temperature to ensure the required temperature is achieved exactly to the degree and irrespective of fluctuations in voltage and water pressure.

The maximum inlet temperature of 70°C is suitable for use with preheated water e.g. from solar heating systems.

Approvals

Zip InLine ES3, ES4 and ES6 are VDE approved to the LVD and EMC directives and CE endorsed.

Zip InLine ES3, ES4 and ES6 have been examined, tested and found when correctly fitted to comply with the requirements of the United Kingdom Water Regulations / Byelaws (Scotland). The products are listed under the WRAS (Water Regulations Advisory Scheme) Water Fittings and Materials Directory.

WARNING

- **Installation, commissioning and maintenance of this appliance must only be carried out by a competent installer who will then be responsible for adhering to all relevant standards and regulations.**
- **The front cover of the appliance must never be opened before disconnecting the appliance from the mains power supply.**
- To protect the appliance, a circuit breaker or fuse must be fitted with a rating suitable for the nominal current of the appliance.
- The appliance must be permanently connected to the supply through an isolating switch with a contact separation of at least 3mm in all poles and be protected by a suitably rated RCD.
- The cross sectional area of the connection cable must be appropriate for the power rating and location of the appliance (See Technical Data Section on page 6).
- The connecting cable must be adequately secured.
-  This appliance must be earthed at all times.
- Check that the power supply is switched off prior to electrical connection.
- The appliance, its wiring and piping must not be modified in any way.
- In case of malfunction isolate the power supply immediately. In case of leaks also isolate the water supply. Repairs must only be carried out by Zip Heaters (UK) Ltd or an authorised Zip service engineer.
- Temperatures in excess of approximately 43°C are perceived as hot, especially by children, and may cause a feeling of burning.
- This appliance can be used by children aged from 8 years and above and persons with reduced physical, sensory or mental capabilities or lack of experience and knowledge if they have been given supervision or instruction concerning the use of the appliance in a safe way and understand the hazards involved.
Children shall not play with the appliance.
Cleaning and user maintenance shall not be made by children without supervision.
- When the appliance has been in use for some time, the fittings may be very hot.
- If inlet temperature is up to 70°C (eg. fed from a solar supply) mixing with cold water will be required to ensure a safe temperature at the outlet.

CAUTION

- Optimum operation is ensured at a water flow pressure of 0.2 to 0.4 MPa (2-4 bar). The appliance must not be subjected to pressure exceeding 1.0 MPa (10 bar).
- The appliance must only be used when correctly installed and in perfect working order.
- The appliance must be installed in a frost-free room and must never be exposed to frost.
- The ES range is not intended for use with thermostatic mixing valves or taps.
- The appliance must be completely filled with water before being switched on.
- Before commissioning for the first time and each time the appliance is emptied (e.g. due to work on the plumbing system or maintenance), the appliance must be vented by opening and closing the hot water tap until all air has been eliminated from the water heater and no more air emerges before re-connecting to the electrical supply.
- The appliance must only be used for heating potable water. The specific water resistance must not fall below the required value indicated on the rating plate. The appliance must not be used for any other purpose.
- Incoming water temperature must not exceed 70°C.
- The Zip InLine is intended for connection to mains supply only. In any other case please contact Zip on 0845 6 005 005 or 0345 6 005 005 for advice.
- The temperature of hot water produced by the ES is dependant upon flow rate, supply voltage and incoming water temperature.
At times of low incoming water temperature (below 12°C) it may be necessary to reduce the flow rate through the appliance to increase the hot water temperature.
- Zip Heaters (UK) Ltd cannot be held liable for any damages caused by failure to observe these instructions.

Dimensions

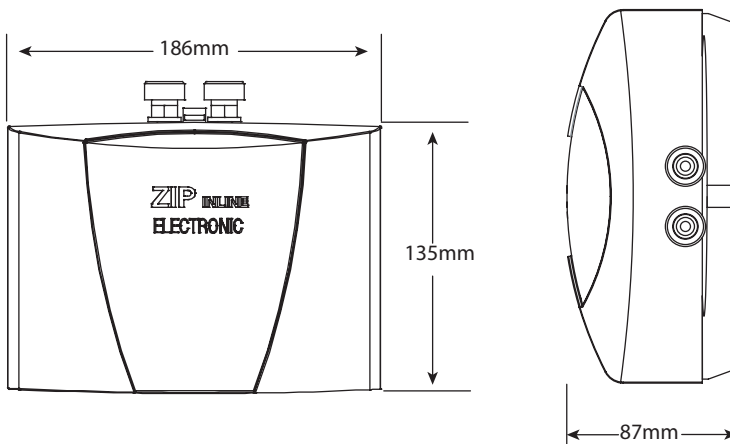

Technical data

Model		Zip InLine		
		ES3	ES4	ES6
Installation		Underbasin		
Declared load profile		XXS		
Energy efficiency class ⁽¹⁾		A		
Energy efficiency (η_{wh}) ⁽¹⁾	[%]	39		
Annual electricity consumption ⁽¹⁾	[kWh]	478	475	
Thermostat temperature setting	[°C]	43		
Specific precautions		See installation and operating instructions		
“Smart” value		0		
Sound power level	[dB(A)]	15		
Rated volume	[l]	0.2		
Weight empty / full	[kg]	1.3/1.5		
Nominal supply voltage	[V-]	230		
Power rating	[kW]	2.8	4.4	5.5
Rated current	[A]	12	19	24
Protection class		IP25		
Element type		Bare wire		
Rated pressure	[MPa]	1.0		
Factory set temperature ⁽²⁾	[°C]	38		
Temperature adjustment range	[°C]	30-43		
Maximum inlet temperature	[°C]	70		
Factory set flow rate @3 bar	[l/min]	2.0	2.5	3.3
Switch on flow rate	[l/min]	1.2	1.5	
Switch off flow rate	[l/min]	1.0	1.3	
Flow rate @ 38°C ⁽³⁾	[l/min]	1.5	2.4	3.0
Minimum differential pressure @ 38°C	[MPa]	0.020	0.045	0.065
Specific water resistance @ 15°C	[Ω .cm]	>1,100	>800	
Packaging dimensions	[mm]	225 x 190 x 130		
Water connections		1/2" BSP		

(1) EU Regulation 812/2013, 814/2013

(2) Subject to incoming water temperature, flow rate and power available.

(3) Based on 12°C supply temperature, 3 bar dynamic pressure and nominal 230V supply voltage.

All data quoted at nominal supply voltage. Standard European voltage tolerances of -6% to +10% may be applied. A minimum water pressure of 0.2 MPa (2 bar) is recommended for optimum performance.

Spare parts.

When ordering spare parts, please always specify the appliance model and serial number.

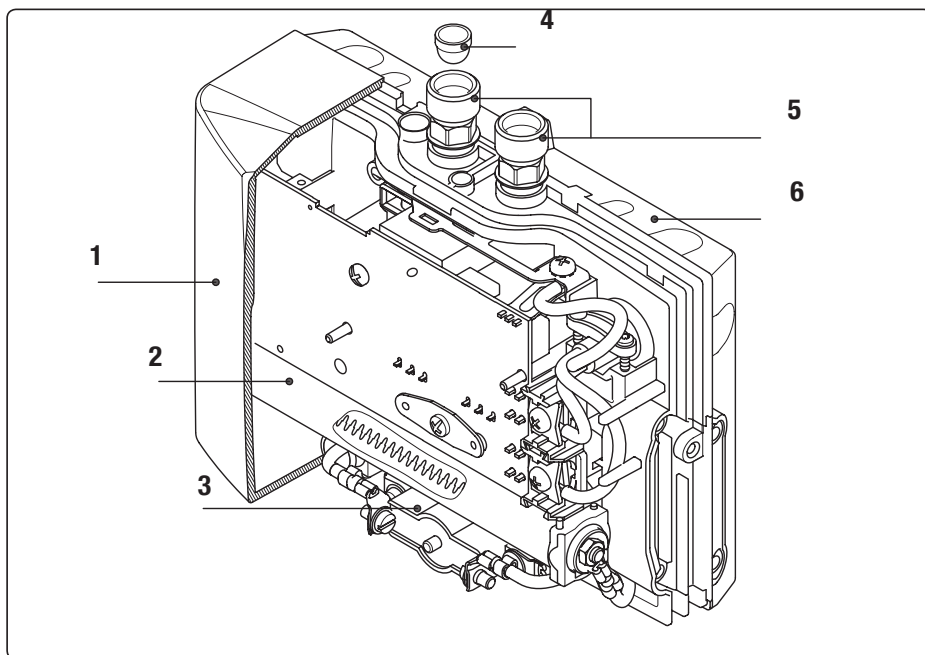

Item	Part No.	Description
1	IN80919	Front cover
2	IN80916	ES3 Heating cartridge
	IN80904	ES4 Heating cartridge
	IN80917	ES6 Heating cartridge
3	IN80911	ES3 Safety Temperature limiter
	IN80912	ES4, ES6 Safety Temperature limiter
4	IN80080	Filter (fine filter)
5	IN80909	Water connection set, including two water connections
6	IN80902	Wall bracket
	IN80910	Temperature sensor (Not shown)
	ZL011	Jet regulator for ES3 and ES4 (Not shown)
	ZL010	Jet regulator for ES6 (Not shown)

Installation Requirements

- These instructions must be read and fully understood before commencing the installation. If in doubt, or in need of further guidance please ring Zip on 0845 6 005 005 or 0345 6 005 005.
- Zip InLine water heaters must be installed by a competent person familiar with electric instantaneous water heaters.
- Installations must comply fully with UK Water Regulations and any Local Authority requirements.
- The electrical installation including earthing and cross bonding should comply with current IEE regulations and any Local Authority requirements.
- Zip InLine water heaters must be installed according to the specification on the rating plate and the technical specifications.
- To protect the appliance, a circuit breaker or fuse must be fitted with a rating suitable for the nominal current of the appliance. (See Technical Data Section on page 6).
- The appliance must be permanently connected to the supply through an isolating switch with a contact separation of at least 3mm in all poles and be protected by a suitably rated RCD.
- The cross sectional area of the connection cable must be in accordance with the power rating of the appliance and the specific requirements of the installation site.
- Take care to protect the wiring from damage during installation and ensure that any uninsulated wiring is not directly accessible after installation.
- Check that the power supply is switched off prior to electrical connection.

Installation site

- The installation site must be free from frost at all times.
- For maintenance work a shut off valve should be installed in the water supply line to the heater.
- The unit should be positioned as close as possible to the outlet to minimise heat loss. The recommended maximum distance is 0.5 metres.
- When considering the location of the heater, consideration should be given to the safe and visible disposal of any water resulting from leaks and seepage. This is particularly relevant when the heater is located in a cupboard or any concealed location.
- For guidance please call Zip Heaters (UK) Ltd on 0845 6 005 005 or 0345 6 005 005.
- Hot and cold water connecting pipes should be WRAS approved and of copper or steel construction. Plastic pipes may only be used if conforming to DIN 16893 Series 2.
- The specific resistance of the supply water must be $>1,100\Omega\text{cm}$ at 15°C for ES3 and $>800\Omega\text{cm}$ at 15°C for ES4 and ES6. The specific resistance can be checked with the local water supply company.

Installing the appliance

1. Secure the wall bracket to the wall with screws and wall plugs supplied (Fig. 1).
2. Place the appliance on the wall bracket and snap into position (Fig. 2).

Note! This appliance is intended for underbasin installation with the water connections pointing vertically upwards.

Fig. 1

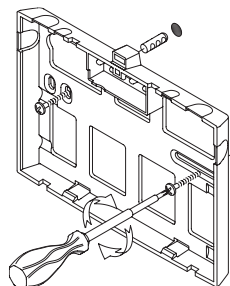

Drill size \varnothing 7 mm.

Use the mounting bracket as a guide for fixing marks.

Drilling width variable:
100mm minimum to
145mm maximum.

Fig. 2

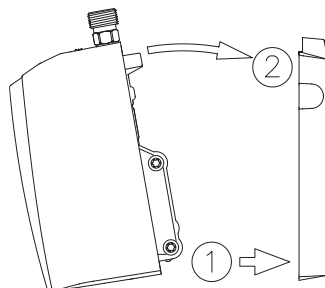

To remove the appliance from the wall bracket.

Put the flat screwdriver tip into the interlock between the water connections until it stops and lift it slightly upwards (Fig. A), tilt the appliance forward by max. 15° (Fig. B) and remove it upwards (Fig. C).

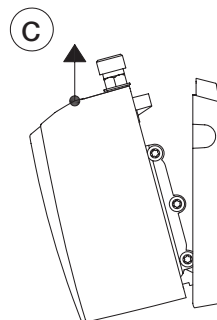
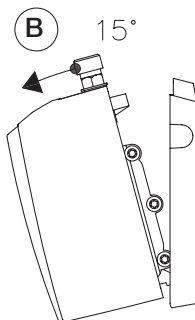
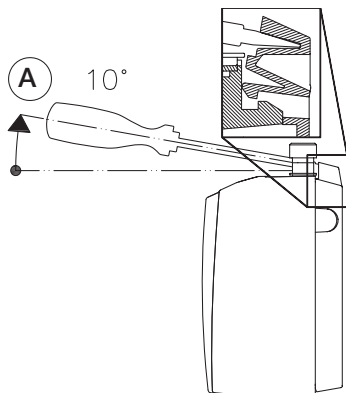

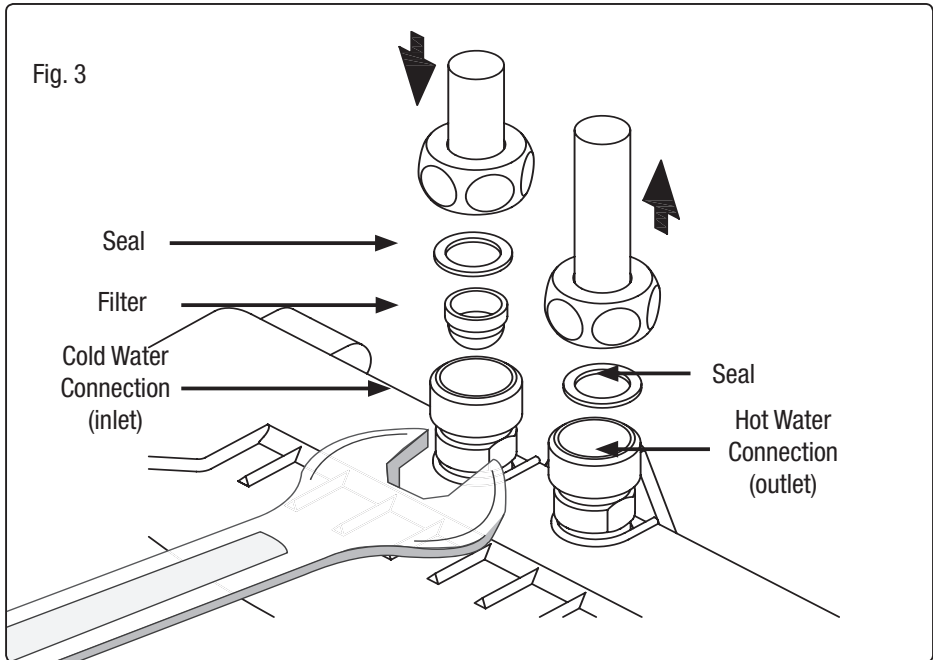

Plumbing connection (Fig. 3)

1. The cold water inlet (blue) and hot water outlet (red) are marked on the rating plate. Connect the appropriate pipes from the tap to the water inlet and outlet accordingly. Avoid exerting any mechanical pressure on the appliance by applying a 13mm spanner on the flats of the inlet and outlet connections when tightening the pipe connectors (Fig.3).
2. When supplying mixer taps a non-return valve must be fitted to the hot water outlet and not to the cold water inlet (fig. 5).
3. A flow control valve may be required on the cold supply to the mixer taps to balance the flow (fig. 5).
4. Thoroughly flush the water supply pipes before connection to remove any water borne debris.
5. Once the water connections have been made, check for any leaks and rectify as necessary.
6. In order to obtain an optimum water jet at low flow rates, always screw the jet regulator supplied with the unit onto the tap outlet. This insert fits commercially available sleeves with an M22 or M24 thread.

Typical installation

Fig. 4/5 show unvented installation with closed outlet tap.

Fig. 4a shows open vented installation

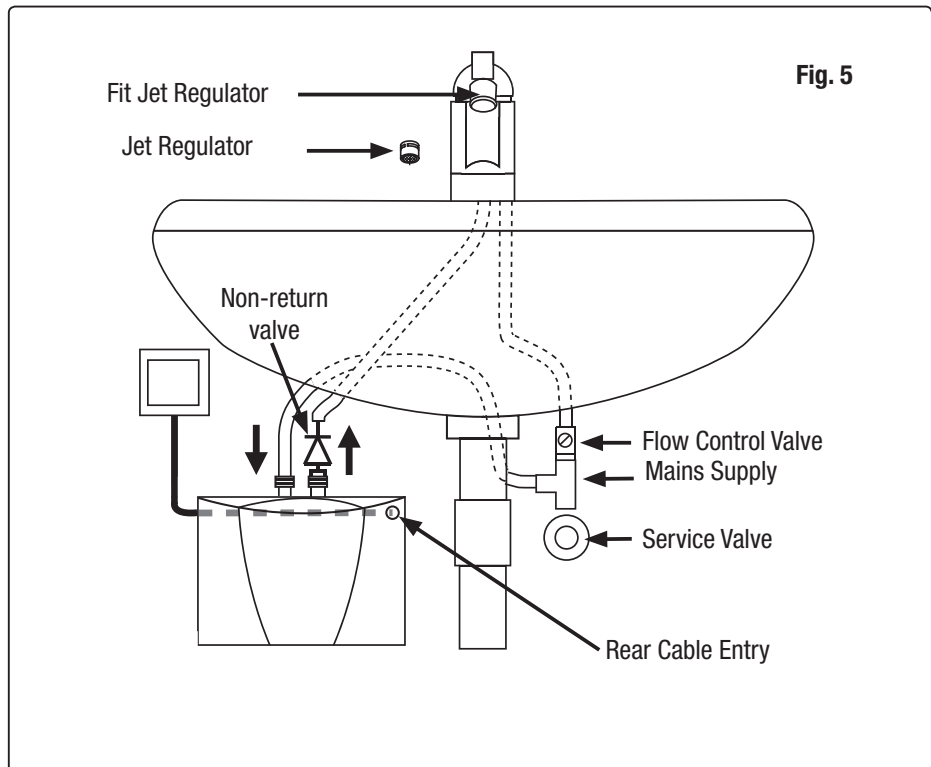
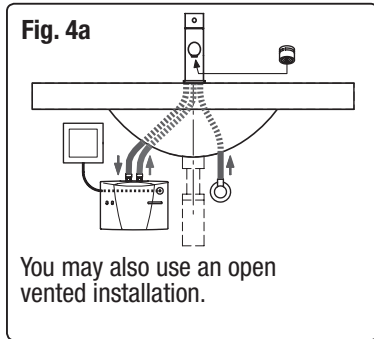

Electrical connection

Do not switch on the electric power at this time.

Installation must be carried out by a competent electrician.

The electrical installation including earthing and cross bonding should comply with current IEE regulations and any Local Authority requirements.

IMPORTANT: The appliance must be installed according to the specification on the rating plate and the technical specifications. Ensure that the voltage marked on the appliance matches the power supply.

WARNING: ⚠️ Check that the power supply is switched off prior to electrical connection!

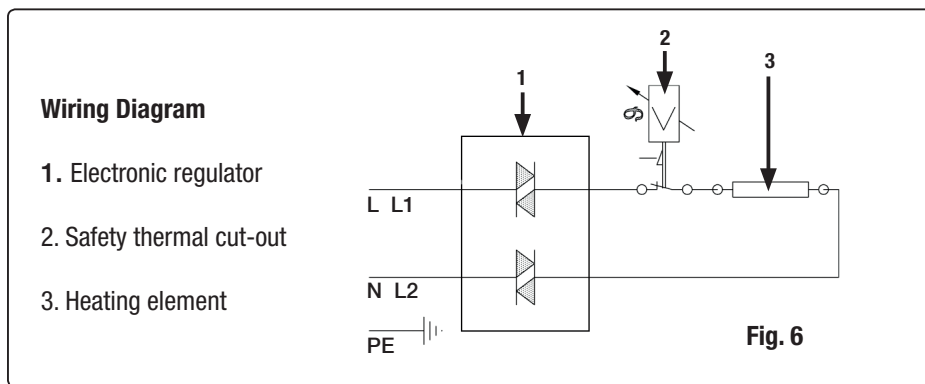

Commissioning

CAUTION ⚠️

To prevent damage to the appliance, the instantaneous water heater must be purged of air before using it for the first time.

PURGING

Before connecting the electrical supply, open and close the hot water tap until the water runs smoothly and no more air emerges.

NOTE! Every time the appliance is drained (e.g. after work on the plumbing system, if there is a risk of frost or following repair work), the heater must be purged in this way before reconnecting the power supply.

WARNING! This appliance must be earthed.

1. Close the circuit breaker to connect the electrical supply. After a short power up delay the water heats up.
2. Check everything is working as it should and the water temperature is achieving the desired temperature. If not follow the guide on pages 13/14.

NOTE! When used to supply a mixer tap a flow restrictor may be required on the cold supply to the tap to balance the flows.

For further information see the Fault Finding table, page 16.

When the unit has been commissioned, explain the functions of the heater to the end user and ensure they know how to use the appliance.

Hand over these instructions for the user to keep.

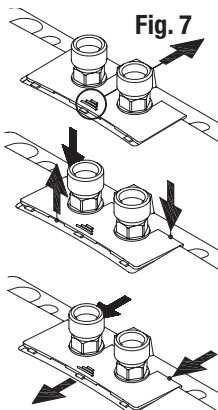

Removing the cover (Fig. 7)

The rating plate and the adjusting screw are located under this cover.

1. Push the cover back towards the wall bracket.
2. At the rear corners press the cover down until the front edge lifts.
3. Remove the cover by pulling forward.

The underside of the cover (Fig. 8) is the data plate and displays model type, serial number etc.

Fig. 8

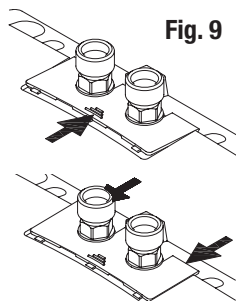
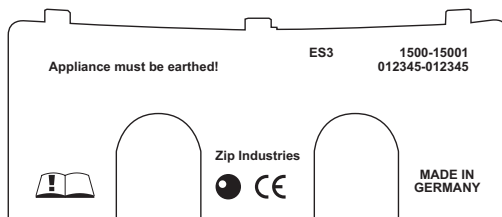

Replacing the cover (Fig. 9)

1. Push the cover towards the wall bracket under the edges of the water connections.
2. Press down the front edge of the cover and move it forward again until it clips into place.

Temperature & flow adjustment

(Authorised Technicians Only)

The factory setting is 38°C. A maximum outlet temperature may be set between 30°C and 43°C.

Water too hot

- If the water is too hot reduce the temperature on the appliance by turning the potentiometer (fig.10 p14) anticlockwise instead of mixing with cold water. Any cold water added is not controlled by the electronic circuitry meaning that precise temperature control can no longer be guaranteed.
- **Note! Adding cold water wastes the energy used to heat it! This unit is not intended for use with a 'thermostatic mixing valve' or tap.**

Water too cold

- Increase the temperature by turning the potentiometer clockwise until the desired temperature is achieved.
- If the desired temperature cannot be achieved the red LED on the PCB will light (solid) to show that the unit cannot achieve the preset temperature. (See LED functions on page 15).
- In this case it will be necessary to adjust the water flow through the unit.
- The flow rate can be adjusted with the adjustment screw (Fig. 11).
- Turning this screw clockwise reduces the flow rate; turning it counter-clockwise increases the flow rate.
- Turn the adjustment screw clockwise; reducing the flow rate until the desired temperature is achieved.

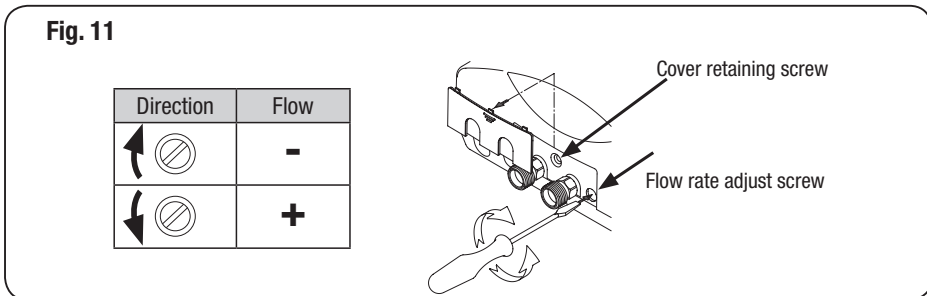
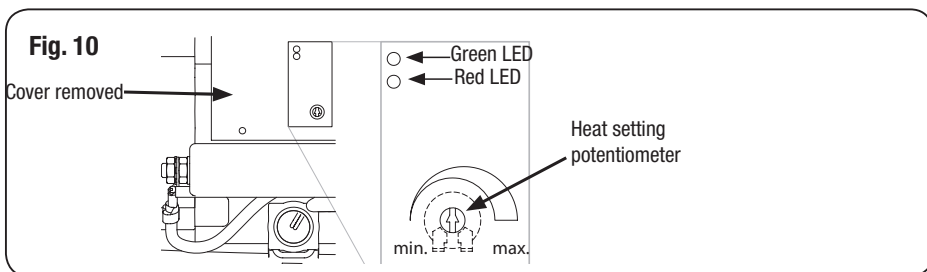

Maintenance

Maintenance and cleaning.

General cleaning

Plastic surfaces and fittings should only be wiped with a damp cloth. Do not use abrasive or chlorine-based cleaning agents or solvents.

The outlet fittings (special tap aerators and shower heads) should be unscrewed and cleaned at regular intervals.

The electrical and plumbing components should be inspected at least every 3 years by a competent person familiar with instantaneous water heaters, to ensure proper functioning and operational safety. Water quality should be considered when determining the frequency of inspection.

NOTE!

Maintenance work must only be carried out by a competent person familiar with instantaneous water heaters.

Outlet fittings (jet regulator Fig. 5 p11) should be unscrewed from the tap nozzle and cleaned at regular intervals.

- Rinse the regulator with water and brush off the debris. For difficult to remove deposits, soak in white vinegar (or a proprietary scale cleaner) for a few minutes and scrub with a toothbrush.
- If any parts are cracked or broken, replace them. If the washer has hardened, it should be replaced.
- With the debris cleaned out, screw the regulator back into the tap.
Hand tightening should be adequate.

The electrical and plumbing components should be inspected regularly by a competent person to ensure proper functioning and operational safety.

Water quality should be considered when determining the frequency of inspection.

Each time the appliance is emptied (e.g. due to work on the plumbing system, if there is a risk of freezing or in case of maintenance), the appliance must be purged by opening and closing the hot water tap until all air has been eliminated from the water heater and no more air emerges before re-connecting to the electrical supply.

Repairs

Repairs should only be carried out by competent persons familiar with electric instantaneous water heaters.

All service work should be performed by an authorized Zip service engineer – for details of the full range of services available call Zip Service on: 0845 6 005 005 or 0345 6 005 005.

When calling for service, please always specify the appliance model and serial number.

The following table will be helpful in determining the causes of some common problems and their solutions

LED Functions

Green LED	
Green LED flashing	Standby mode
Green LED constantly on	Appliance is heating water
Red LED	
Red LED constantly on	The required outlet temperature cannot be achieved at maximum power
Red LED flash code:	
Long- short-long-short-long	Heating element defective
Long-short-short-short	Temperature sensor faulty
Long-short-long	Air bubble in system

Problem	Possible cause	Solution
No water flows	Water supply is turned off	Open the main water valve / shut off valve
Water flows more slowly than expected	The Jet Regulator is not fitted	Fit the correct Jet Regulator (see Fig. 5)
	Water pressure is not sufficient	Check the water flow pressure, check the water flow adjustment. See fig. 11
	Dirt in the pipes	Remove any dirt from the filter, valves and / or taps, check the technical data
The heater switches itself on and off	Water pressure is varying, flow rate is too low	Remove any dirt, increase the flow water pressure, close other taps, open the shut off valve further
Water remains cold	Water pressure is not sufficient	Adjust the water flow see fig. 11 Open the shut-off valve. Fit the correct jet regulator (see Fig. 5) check water pressure
	Dirt in the inlet or outlet	Remove dirt from the inlet and outlet
	Temperature sensor defective	Replace temperature sensor (authorised technician)
	Heating element defective	Replace heating element (authorised technician)
Hot water temperature varies	Supply voltage varies	Check the supply voltage
	Water connections reversed	Check installation
Hot water temperature too low	Flow rate is too high	Adjust the flow rate (see adjusting flow rate on page 13 fig. 11)
	Inlet temperature is too low	Adjust temperature potentiometer. (see adjusting potentiometer page 13 fig. 10) (Authorised technician)

Warranty

The Zip appliance you have chosen is precision-built from the finest materials available and should give many years of trouble free service.

Certain warranties may be implied by law into your contract with Zip.

The warranty provided below is additional to these implied warranties and nothing set out below shall limit your statutory rights or rights at law.

Zip Heaters (UK) Ltd warrants that, should any part fail within 12 calendar months of installation, that part will be repaired or replaced free of charge by Zip or its Distributor or Service Provider, except as set out below, provided the appliance is installed and used strictly in accordance with the instructions supplied, and that failure is not due to accident, misuse, abuse, unsuitable water conditions, or to any alteration, modification or repair by any party not expressly nominated by Zip.

No costs are payable by the customer other than any mileage or travelling-time charges incurred by a Zip Service Provider or the cost of removal, cartage and re-installation of any component of the appliance if it needs to be returned for repair to Zip or its Distributor.

This warranty does not cover damage resulting from non-operation of the appliance or consequential damage to any other goods, furnishings or property.

Zip does not exclude, restrict or modify any liability that cannot be excluded, restricted or modified or which cannot, except to a limited extent, be excluded, restricted or modified as between the owner or user and Zip under the laws applicable.

Furthermore, this warranty does not displace any statutory warranty, but, to the extent to which Zip is entitled to do so, the liability of Zip under any statutory warranty will be limited at Zip's option to the replacement of the appliance or supply of equivalent appliance, the payment of the cost of replacing the appliance or acquiring an equivalent appliance, or the payment of the cost of having the appliance repaired or the repair of the appliance.

NOTE: It is our policy to continually improve products and as such we reserve the right to alter data, specifications and component parts without prior notice.

To ensure you have the latest revision of this instruction manual, please visit www.zipheaters.co.uk to download the latest copy.

IMPORTANT: No liability is accepted for incorrect use of this product.

End of Life Disposal

The use of this crossed out wheeled bin logo indicates that this product needs to be disposed of separately to any other household waste.



Within each of the European Union member countries, provisions have been made for the collection and recycling of unwanted electrical and electronic equipment. In order to preserve our environment we ask that you dispose of this product correctly.

Please contact Zip Customer Service for advice on
0845 6 005 005 or 0345 6 005 005.



The terms 'Zip' and 'InLine'
are registered trademarks

Zip Heaters (UK) Ltd
14 Bertie Ward Way
Dereham
Norfolk
NR19 1TE

Telephone: 0845 6 005 005
Mobile: 0345 6 005 005
Fax: 01362 692448
Web: www.zipheaters.co.uk



9120-14111