

## Zip HydroTap® G4

**Boiling** | **Chilled** | **Sparkling** | **Filtered** | **Instantly**  
**Commercial models BCS100/75G4, BCS140/75G4**

With new Zip G4 power-saving technology and Zip 0.2 micron filtration.



Can be installed away from any sink with the optional ZT008 'font' accessory.

**Boiling and chilled filtered water, instantly, plus “sparkling” chilled filtered water instantly from a “compact” G4 Command-Centre™.**

### 1. Saving energy

- Superior Zip G4 thermal insulation now significantly reduces standby energy consumption.
- Power-Pulse™ technology maintains boiling water to within 0.2°C of set temperature.
- Adjustable boiling temperature set-point.
- Sleeps or “powers-off” after two hours of non-use, to minimise daily power consumption.
- Automatically sleeps when the kitchen goes dark, for added power savings overnight.
- Integral 24/7 automatic timer turns power on and off over weekends or weekday periods.

### 2. User safety

- Choice of fingertip control for fast cup filling (lever down) or hands-free pot filling (lever up).
- Operate both levers simultaneously for access to chilled filtered “sparkling” drinking water.
- Can be set to finger-thumb operation to access boiling water, eliminating risk of accidental use.
- Can also be set to boiling water “isolation mode” for total safety when kitchen is unattended.

### 3. Healthier drinking

- Inbuilt Zip 0.2 micron NSF-certified filter puts crystal-clear better-tasting water on tap, filtering out chlorine taste and odour and impurities as tiny as one five-thousandth of a millimetre, including protozoan cysts such as Cryptosporidium, but does not remove beneficial fluoride.
- Free-Flow™ bottle filling: for continued supply of filtered water even when chilling capacity is exceeded. (Chilled only).



Simple to install at any kitchen sink.



New under-sink Zip G4 Command-Centre™ leads the world in energy-saving technology, has a pin-code protected touch-screen to simplify adjustments and automatically monitors performance to give an operating history, if ever required.

### Warranty.

24 months, plus additional 36 months boiling tank warranty.



### Typical specification

Under-sink boiling and chilled and sparkling filtered water appliance equipped with two way lever action electronic tap head. Integral 5 bar pressure limiting and Dual Check valve, NSF certified 0.2 micron filter, air cooled refrigeration system with cleanable lint filter. Full colour interactive touch screen display with pin code protection, 2 boiling water safety modes, 3 energy saving modes including a sensor activated “sleep when its dark” feature. Upgradable boiling water capacity with additional “Booster” module (100 model only) and the ability to adapt to provide approx. 55°C hot water for sanitary use to a secondary outlet with additional “Vented Mixer” kit.



## Zip HydroTap® G4

Boiling | Chilled | Sparkling | Filtered | Instantly

Model	Boiling Cups/hr	Chilled glasses/hr	Rating (kW) @ 230V	Dimensions W x D x H (mm)
BCS100/75G4	100	75	2.15	280 x 470 x 335
BCS140/75G4	140	75	2.15 + 2.20 (b)	280 x 470 x 335

Standard Cup = 167 ml. Standard Glass = 200 ml.

(a) Order codes shown here are for the models installed on a sink. To install on a 'font' also specify a font kit: order code ZT008.

(b) Model BCS140/75G4 is installed with an externally mounted 2.2 kW booster unit and must be connected to two separate 13 amp fused spurs.

### Boiling System

Open outlet, vented system, factory set to operate at 98°C.

Flow rate 4.0 l/min.

### Chilling System

Fan-cooled condenser type, factory set to operate at 5-10°C.

Flow rate above 2.5 bar water supply pressure.

Chilled 3.0 - 4.0 l/min.

Sparkling 1.3 - 1.8 l/min.

Refrigerant R134a.

### Location

Tap must be positioned so that it drains into a suitable sink, or be installed on the optional "tap font kit" which is plumbed to waste.

Tap should be situated as closely as possible to, and directly above the under-sink Command Centre. Maximum distance from the base of the tap to the Command Centre is one metre. Command Centre must have clearances as shown on the drawings.

Ventilation accessories (supplied) must be installed as per instructions.

### Approvals

CE endorsed.

### Plumbing

Must be installed in accordance with UK Water Supply Regulations.

Designed for direct connection to a potable (drinkable) cold water supply with a minimum pressure of 2.5 bar (also 2.5 bar if fitted with booster unit or scale filtration). A 5 bar pressure limiting valve is fitted internally. An isolating valve should be installed between the water supply and the Command Centre.

### Electrical

Installation must comply with current IEE regulations.

Model 100/75 to be wired to a double pole 13 amp fused spur.

Model 140/75 is installed with an externally mounted 2.2kW booster unit and must be connected to two separate double pole 13 amp fused spurs.

### Caution

In hard water areas where mineral scale accumulation may be an issue, consideration should be given to the maintenance required. We recommend use of the Zip Professional high performance limescale filtration system.

### Carbon Dioxide

The disposable CO<sub>2</sub> gas cylinder (supplied) must be secured in an upright position in a ventilated area not less than 38 cubic metres. Each cylinder contains 1kg of CO<sub>2</sub>. See website for gas cylinder MSDS sheet.

### Accessories

ZT008 – Zip G4 font installation kit.

ZT402 – Zip 0.2 micron replacement filter.

ZT400 – Replacement CO<sub>2</sub> cylinder.

ZT401 – Regulator converter.

### Scale filters

FL2300G4 KIT – light commercial use.

FL3600G4 KIT – normal commercial use.

FL6000G4 KIT – heavy commercial use.

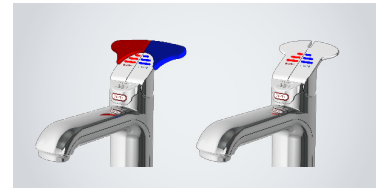

To order any model to be supplied with extension levers and Braille pads, add D to the end of the Order Code.

### Technical Support

Contact Zip on:

Tel: 0845 6 005 005 / 0345 6 005 005

e-mail: [service@zipheaters.co.uk](mailto:service@zipheaters.co.uk)

### Five Year Warranty

Appliance warranty

24 months, plus additional

36 months boiling tank warranty.

See website for details.

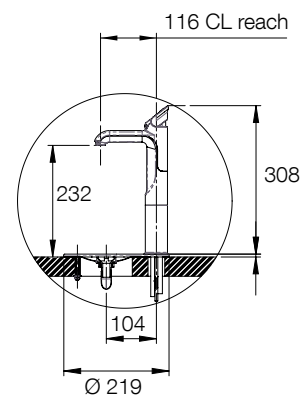
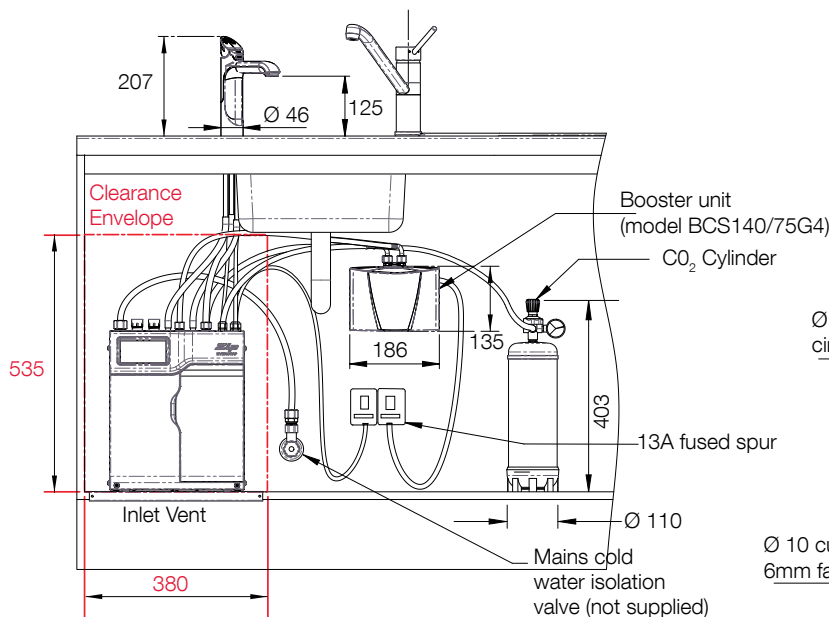
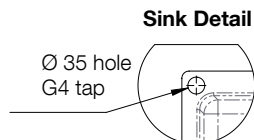

Font Detail

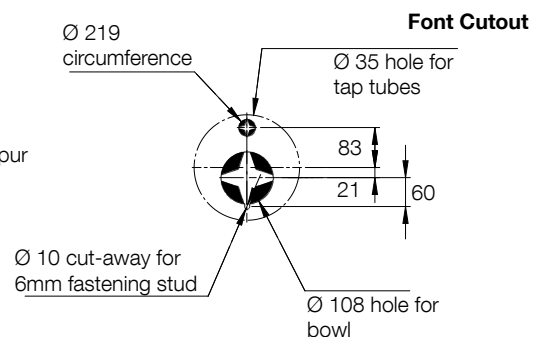

Font Cutout

Dimensions in mm