

## Lynx 400 Heavy Duty Contact / Panini Grills

### Key Features

- Type: Electric
- Counter top unit
- Thermostatic temperature control (six positions)
- Upper and lower non-stick plates
- Timer - 20 min
- Fat collection tray to rear (removable)
- Supplied with plate scraper



GG1R

### Construction

- Body: stainless steel grade 430
- Plates: cast aluminium (coated PTFE)

### Available Options

- GG1 Smooth upper and lower plates
- GG1P Ribbed upper and lower plates
- GG1R Ribbed upper and smooth lower plates

### Available Accessories

- SS1 – Sandwich spacer
- OS1 – Omelette spacer

## Specifications

Model	GG1/GG1P/GG1R
External height (mm)	260
External width (mm)	390
External depth (mm)	380
Usable plate area w x d (mm)	345 x 270
Net weight unpacked (kg)	21.5
Gross weight packed (kg)	26
Shipping volume (m <sup>3</sup> )	0.113
Total power rating (kW)	3.0
Electrical supply 1N~+E 230V 50-60Hz Current Rating (A)	13

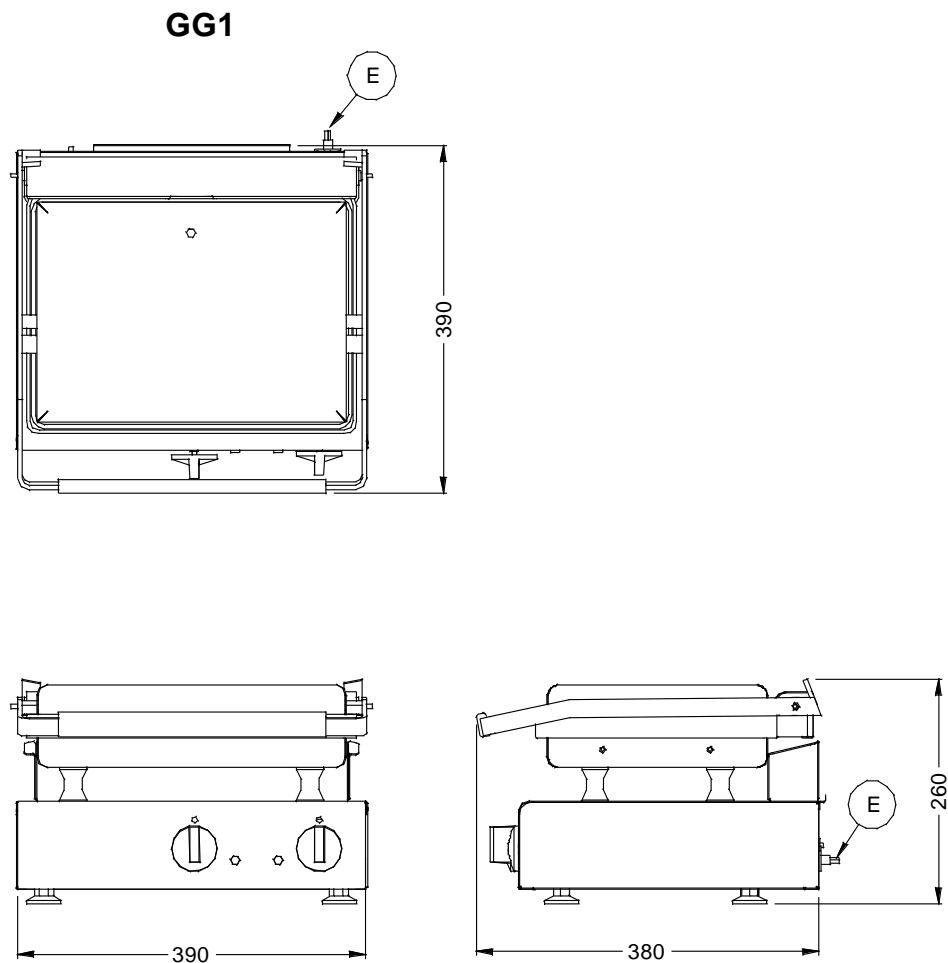

Lincat Limited, Whisby Road,  
Lincoln LN6 3QZ,  
United Kingdom

UK Sales Tel: 01522 875500 UK Spares Tel: 01522 875510 UK General Tel: 01522 875555  
 UK Fax: 01522 875530 International Sales Tel: +44 1522 503250 International Fax: +44 1522 875530  
 Website: [www.lincat.co.uk](http://www.lincat.co.uk) UK Sales e-mail: [sales@lincat.co.uk](mailto:sales@lincat.co.uk) International Sales e-mail: [export@lincat.co.uk](mailto:export@lincat.co.uk)



Document ref:  
LYNXGG1\_GG1P\_GG1R  
Issue date: Feb-17