

## Lynx 400 Salamander Grill

### Key Features

- Type: Electric
- Counter top unit or wall – mounted
- Simmerstat temperature control
- Supplied with toasting rack and grill pan



LGT

### Construction

- Body: stainless steel grade 430
- Rack: chrome plated
- Handles: steel coil

### Available Options

- N/A

### Available Accessories

- BR15 – Wall mounting brackets

## Specifications

Model	LGT
External height (mm)	328
External width (mm)	551
External depth (mm)	322
Grill tray size w x d (mm)	415 x 230
Net weight - unpacked (kg)	12
Gross weight - packed (kg)	16
Shipping volume (m <sup>3</sup> )	0.145
Total power rating (kW)	3
Electrical supply 1N~+E 230V 50-60Hz Current Rating (A)	13

LGT

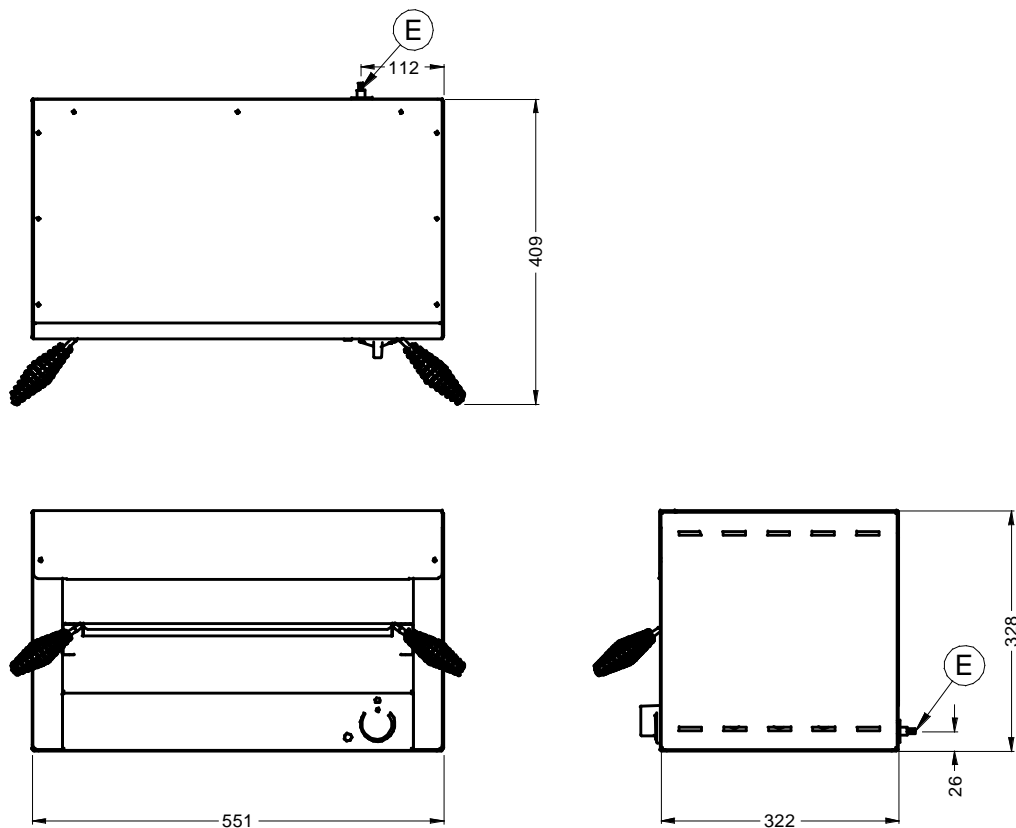

Lincat Limited, Whisby Road,  
Lincoln LN6 3QZ,  
United Kingdom

UK Sales Tel: 01522 875500 UK Spares Tel: 01522 875510 UK General Tel: 01522 875555  
 UK Fax: 01522 875530 International Sales Tel: +44 1522 503250 International Fax: +44 1522 875530  
 Website: www.lincat.co.uk UK Sales e-mail: sales@lincat.co.uk International Sales e-mail: export@lincat.co.uk



Document ref:  
LYNXLGT  
Issue date: Feb-17