

## Seal Heated Bases

### Key Features

- Type: Heated counter-top unit
- Thermostatic temperature control
- Height adjustable feet



HR2

### Construction

- Body: stainless steel grade 430
- Hob top: aluminium

### Available Options

- Choice of four widths

### Available Accessories

- Bains marie adaptors including 2/3 GN containers (65mm deep) and lids

## Specifications

Model	HB1	HB2	HB3	HB4
External height (mm)	115	115	115	115
External width (mm)	381	754	1094	1434
External depth (mm)	531	531	531	531
Usable heated surface w x d (mm)	302 x 500	748 x 500	1088 x 500	1428 x 500
Net weight unpacked (kg)	7	11	15	19
Gross weight packed (kg)	10	14	18	23
Shipping volume (m <sup>3</sup> )	0.145	0.13	0.179	0.232
Total electrical power rating (kW)	0.5	1.0	1.4	1.75
Electrical supply 1N~+E 230V 50-60Hz Current Rating (A)	2.2	4.3	6.1	7.6

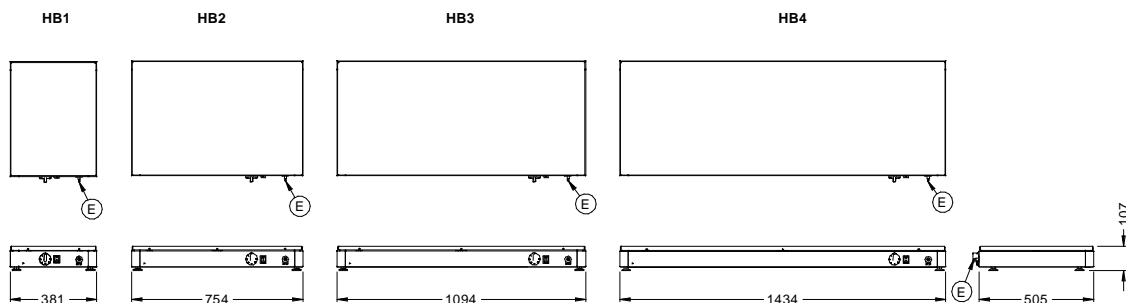

Lincat Limited, Whisby Road,  
Lincoln LN6 3QZ,  
United Kingdom

UK Sales Tel: 01522 875500 UK Spares Tel: 01522 875510 UK General Tel: 01522 875555  
 UK Fax: 01522 875530 International Sales Tel: +44 1522 503250 International Fax: +44 1522 875530  
 Website: www.lincat.co.uk UK Sales e-mail: sales@lincat.co.uk International Sales e-mail: export@lincat.co.uk



Document ref:  
SEALHB1\_HB2\_HB3\_HB4  
Issue date: Feb-17