

Seal Heated Displays with Gantry

Key Features

- Type: Heated counter-top unit
- Thermostatic temperature control
- Overhead halogen heat lamps with separate control
- Sneeze screen
- Height adjustable feet



IND4

Construction

- Body: stainless steel grade 430
- Hob top: aluminium
- Sneeze screen: toughened safety glass

Available Options

- Choice of three widths

Available Accessories

- Bains marie adaptors including 2/3 GN containers (65mm deep) and lids:

Specifications

Model	LD2	LD3	LD4
External height (mm)	562	562	562
External width (mm)	790	1130	1470
External depth (mm)	538	538	538
Usable heated surface w x d (mm)	748 x 500	1088 x 500	1428 x 500
Net weight unpacked (kg)	18	24	30
Gross weight packed (kg)	23	30	36
Shipping volume (m ³)	0.465	0.632	0.632
Number of heat lamps	1	2	2
Total electrical power rating (kW)	1.5	2.4	2.75
Electrical supply 1N~+E 230V 50-60Hz Current Rating (A)	6.5	10.4	12.0

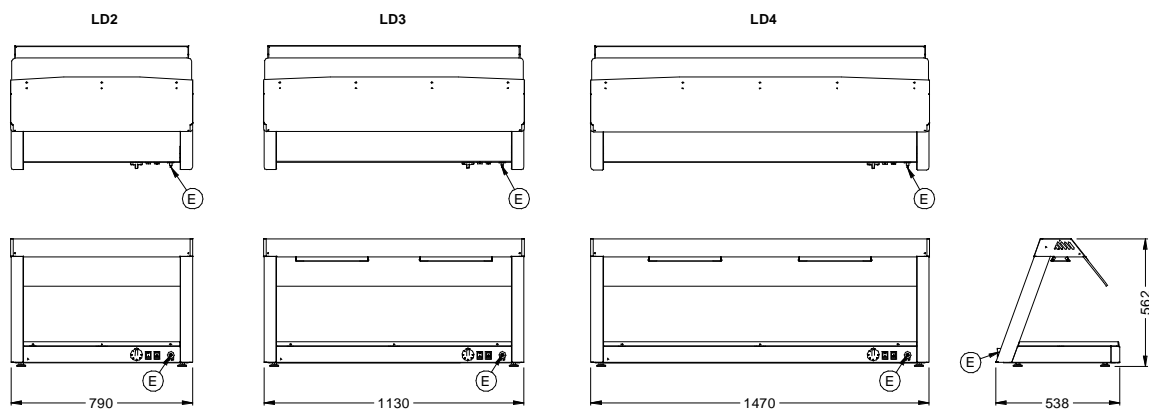

Lincat Limited, Whisby Road,
Lincoln LN6 3QZ,
United Kingdom

UK Sales Tel: 01522 875500 UK Spares Tel: 01522 875510 UK General Tel: 01522 875555
 UK Fax: 01522 875530 International Sales Tel: +44 1522 503250 International Fax: +44 1522 875530
 Website: www.lincat.co.uk UK Sales e-mail: sales@lincat.co.uk International Sales e-mail: export@lincat.co.uk



Document ref:
SEALLD3_LD4_LD4
Issue date: Feb-17