

Seal Pie Cabinets

Key Features

- Type: Heated counter-top unit
- Thermostatic temperature control
- Cabinet temperature up to 95°C
- Sliding rear doors
- Height adjustable feet
- Supplied with four chrome plated shelves



LPW/LR

Construction

- Body: stainless steel grade 430
- Front and doors: toughened safety glass
- Shelves: chrome plated

Available Options

- Unit without internal lighting and humidity feature (LPW)
- Unit with internal lighting and humidity feature (LPW/LR)
- 60 Hz supply (price on request)

Available Accessories

N/A

Specifications

Model	LPW	LPW/LR
Internal lighting and humidity feature	No	Yes
External height (mm)	520	520
External width (mm)	710	710
External depth (mm)	330	330
Usable capacity h x w x d (mm)	400 x 605 x 275	400 x 605 x 275
Shelf size w x d (mm)	605 x 275	605 x 275
Net weight unpacked (kg)	28	28
Gross weight packed (kg)	30	30
Shipping volume (m ³)	0.277	0.277
Total electrical power rating (kW)	0.75	0.80
Electrical supply 1N~+E 230V 50-60Hz Current Rating (A)	3.2	3.3

LPW LPW/LR

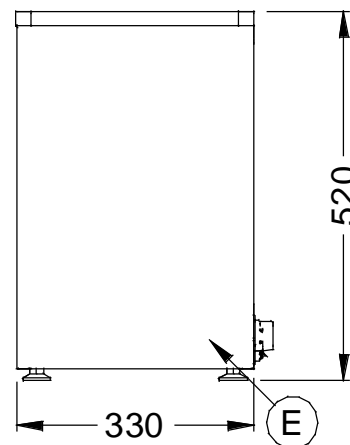
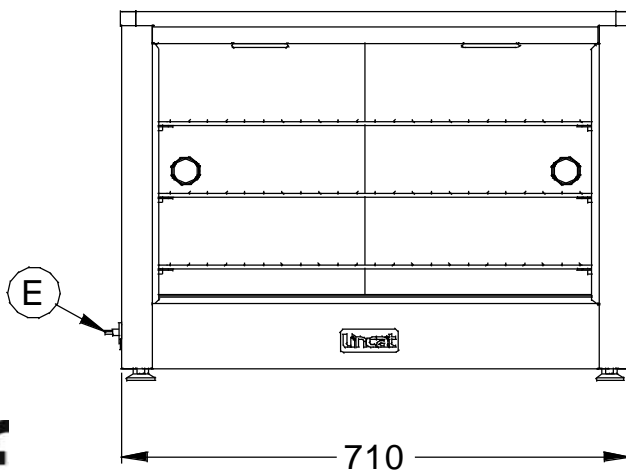
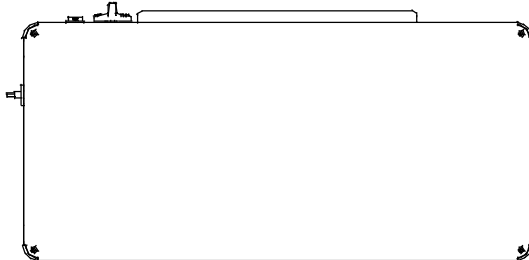

Lincat Limited, Whisby Road,
Lincoln LN6 3QZ,
United Kingdom

UK Sales Tel: 01522 875500 UK Spares Tel: 01522 875510 UK General Tel: 01522 875555
 UK Fax: 01522 875530 International Sales Tel: +44 1522 503250 International Fax: +44 1522 875530
 Website: www.lincat.co.uk UK Sales e-mail: sales@lincat.co.uk International Sales e-mail: export@lincat.co.uk



Document ref:
SEALLPW_LPWLR
Issue date: Feb-17