

Silverlink 600 Chip Scuttle with Gantry

Key Features

- Type: Electric
- Counter top unit
- Heated by halogen light above and element below
- Removable container and perforated drain plate
- Simmerstat temperature control



CS4/G

Construction

- Body: stainless steel grade 430
- Container: stainless steel grade 304
- Drain plate: stainless steel grade 430

Available Options

- N/A

Available Accessories

- Various pedestals and stands

Specifications

Model	CS4/G
External height (mm)	645
External width (mm)	450
External depth (mm)	600
Net weight unpacked (kg)	17
Gross weight packed (kg)	22
Shipping volume (m ³)	0.382
Total power rating (kW)	1
Electrical supply 1N~ + E 230V 50-60Hz Current Rating (A)	4

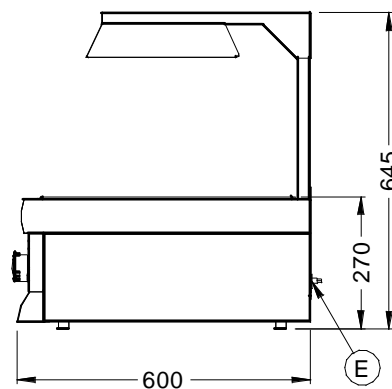
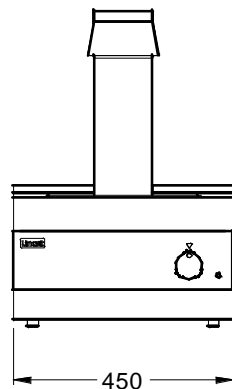
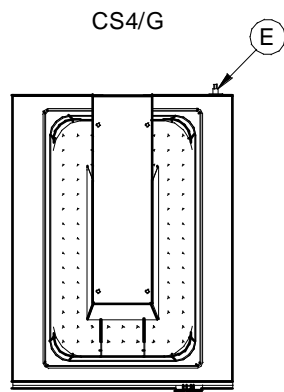

Lincat Limited, Whisby Road,
Lincoln LN6 3QZ,
United Kingdom

UK Sales Tel: 01522 875500 UK Spares Tel: 01522 875510 UK General Tel: 01522 875555
 UK Fax: 01522 875530 International Sales Tel: +44 1522 503250 International Fax: +44 1522 875530
 Website: www.lincat.co.uk UK Sales e-mail: sales@lincat.co.uk International Sales e-mail: export@lincat.co.uk



Document ref:
SLINKCS4G
Issue date: Feb 17