

Silverlink 600 Counter Top Fryers

Key Features

- Type: Electric
- Counter-top units
- Front mounted control knob
- Thermostatic temperature control (130°C – 190°C)
- Hinged elements with safety cut-out
- Fail-safe temperature cut-outs
- Drainage taps to front
- Supplied with baskets, batter plates and lids
- Nitrile rubber feet



DF66

Construction

- Body: stainless steel grade 430
- Tank: stainless steel grade 304
- Baskets: nickel plated spun wire

Available Options

- Choice of power ratings and single or twin tank models

Available Accessories

- BA96 - half size basket
- Various pedestals and stands

Specifications

Model	DF66	DF612	DF618	DF66/ST
No of tanks	2	2	2	1
No of baskets	2	2	2	3
Oil capacity (litres)	2 x 9	2 x 9	2 x 9	20
External height (mm)	335	335	335	335
External width (mm)	600	600	600	600
External depth (mm)	600	600	600	600
Net weight unpacked (kg)	24	25	27	22
Gross weight packed (kg)	30	31	33	28
Shipping volume (m ³)	0.255	0.255	0.255	0.255
Total electrical power rating (kW)	6.0	12.0	18.0	6.0
Electrical supply 1N~+E 230V 50-60Hz				
Current Rating (A)	2 X 13	2 X 26	2 X 39	26
Electrical supply 3N~+E 400V 50-60Hz		L1 2 X 13 L2 2 X 13 L3 N/A	L1 2 X 13 L2 2 X 13 L3 2 X 13	L1 13 L2 13 L3 N/A
Current Rating (A)	N/A			

DF66
DF612
DF618

DF66/ST

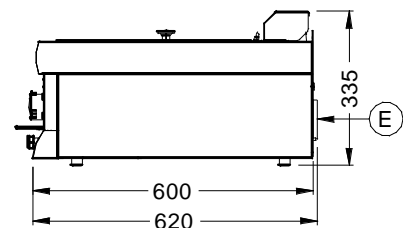
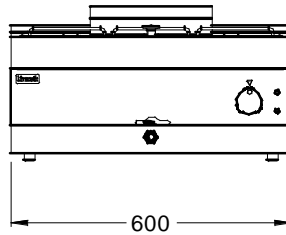
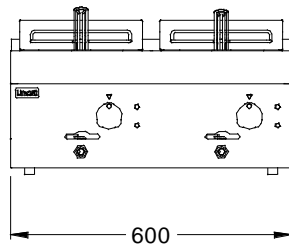
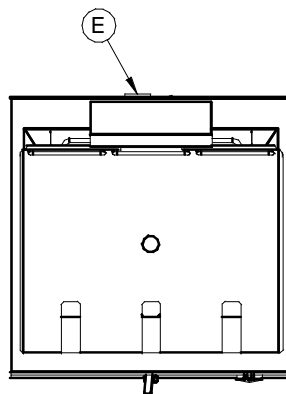
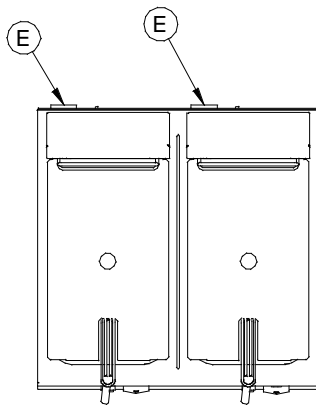

Lincat Limited, Whisby Road,
Lincoln LN6 3QZ,
United Kingdom

UK Sales Tel: 01522 875500 UK Spares Tel: 01522 875510 UK General Tel: 01522 875555
UK Fax: 01522 875530 International Sales Tel: +44 1522 503250 International Fax: +44 1522 875530
Website: www.lincat.co.uk UK Sales e-mail: sales@lincat.co.uk International Sales e-mail: export@lincat.co.uk



Document ref:
SLINKDF66_DF66ST_DF612_DF618
Issue date: Feb 17