

Silverlink 600 Boiling Tops

Key Features

- Type: Electric
- Counter top unit
- Sealed hob top
- Automatic power reduction if pan boils dry or is removed
- Simmerstat temperature control (six position)
- Hotplates 190mm / 7 1/2" diameter
- Nitrile rubber feet



HT7

Construction

- Body: stainless steel grade 430

Available Options

- Choice of 2, 4 and 6 plate models

Available Accessories

- Various pedestals and stands

Specifications

Model	HT3	HT6	HT7
External height (mm)	290	290	290
External width (mm)	300	600	750
External depth (mm)	600	600	600
Number of hot plates	2	4	4
Hotplate power ratings (kW)	2 x 1.5	2 x 1.5, 2 x 2	2 x 1.5, 2 x 2
Net weight (kg)	10	17	19
Gross weight (kg)	14	23	26
Shipping volume (m ³)	0.143	0.255	0.311
Total electrical power rating (kW)	3.0	7.0	7.0
Electrical supply 1N~+E 230V 50-60Hz Current rating (A)	13.0	30.5	30.5
Electrical supply 3N~+E 400V 50-60Hz Current Rating (A)	N/A	L1 - 9.0 L2 - 13.0 L3 - 9.0	L1-9.0 L2-13.0 L3-9.0

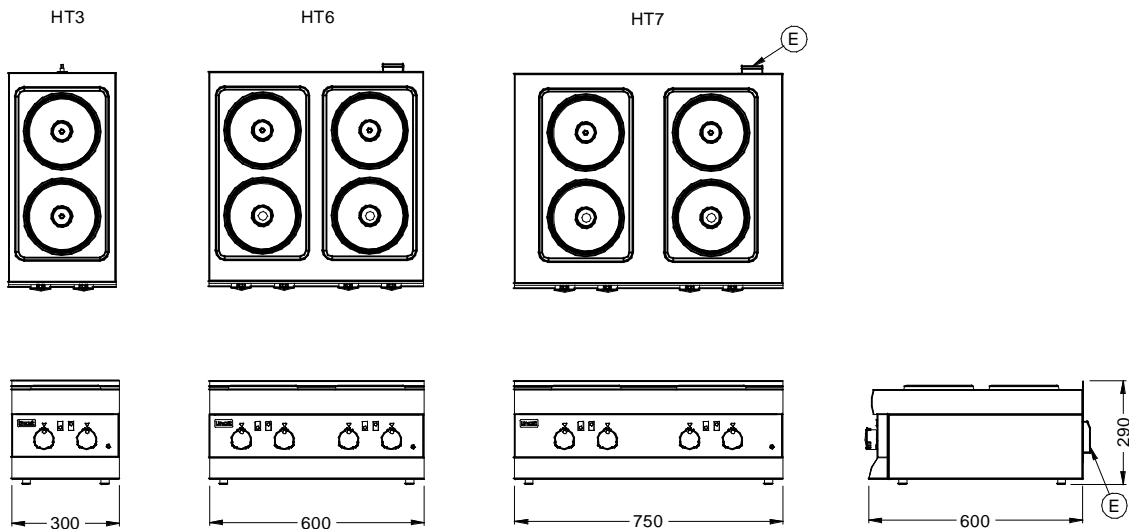

Lincat Limited, Whisby Road,
Lincoln LN6 3QZ,
United Kingdom

UK Sales Tel: 01522 875500 UK Spares Tel: 01522 875510 UK General Tel: 01522 875555
 UK Fax: 01522 875530 International Sales Tel: +44 1522 503250 International Fax: +44 1522 875530
 Website: www.lincat.co.uk UK Sales e-mail: sales@lincat.co.uk International Sales e-mail: export@lincat.co.uk



Document ref:
SLINKELECHT3_HT6_HT7
Issue date: Feb 17