

## Silverlink 600 Oven Range

### Key Features

- Type: Electric
- Sealed hob
- Simmerstat temperature control of hotplates (six positions)
- Thermostatic temperature control of oven (50 – 250°C)
- Hotplates 190mm / 7½" diameter
- Automatic power reduction if pan boils dry or is removed
- Fan assisted oven
- Supplied with 2 shelves
- 4 shelf positions
- Removable oven base
- Two side-hinged doors (180° opening)
- Height adjustable legs (at front) and castors (at rear)



FSI R9C

### Construction

- Body: stainless steel grade 430
- Oven liner: enamelled steel
- Shelves: chrome plated
- Side racks: chrome plated

### Available Options

N/A

### Available Accessories

N/A

## Specifications

Model	ESLR9C
External height (mm)	934
External width (mm)	900
External depth (mm)	670
Usable oven dimensions (mm) W x D x H	720 x 350 x 430
Shelf dimensions (mm) W x D	670 x 340
Oven capacity (m <sup>3</sup> )	0.093
Net weight unpacked (kg)	95
Gross weight packed (kg)	106
Shipping volume (m <sup>3</sup> )	1.171
Hotplate power ratings (kW)	3 x 2, 3 x 1.5
Oven power rating (kW)	2 x 3
Total electrical power rating (kW)	16.5
Electrical supply 1N~+E 230V 50-60Hz Current Rating (A)	N/A
Electrical supply 3N~+E 400V 50-60Hz Current Rating (A)	L1 27 L2 27 L3 15

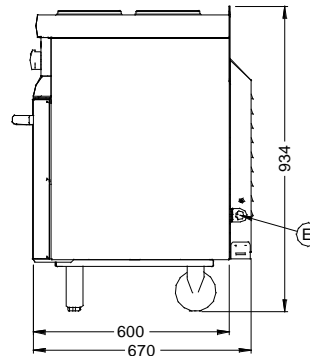
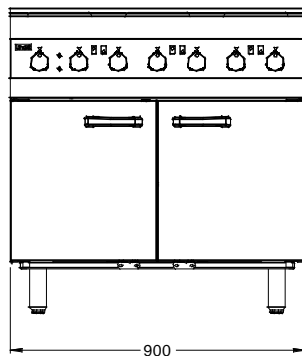
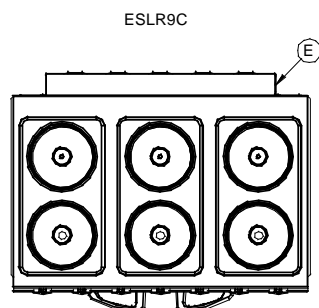

Lincat Limited, Whisby Road,  
Lincoln LN6 3QZ,  
United Kingdom

UK Sales Tel: 01522 875500 UK Spares Tel: 01522 875510 UK General Tel: 01522 875555  
 UK Fax: 01522 875530 International Sales Tel: +44 1522 503250 International Fax: +44 1522 875530  
 Website: [www.lincat.co.uk](http://www.lincat.co.uk) UK Sales e-mail: [sales@lincat.co.uk](mailto:sales@lincat.co.uk) International Sales e-mail: [export@lincat.co.uk](mailto:export@lincat.co.uk)



Document ref:  
SLINKESLR9C  
Issue date: Feb-17