

Silverlink 600 Free Standing Fryers

Key Features

- Type: Gas
- Thermostatic temperature control 110°C to 190°C
- Flame failure device
- Top temperature cut-out
- Cool zone
- Piezo ignition
- Supplied with wire baskets, batter plates and lids
- Millivolt control system (no need for electrical connection)
- Supplied on height adjustable legs
- Finned heat exchange system



110

Construction

- Body: stainless steel grade 430
- Baskets: nickel plated spun wire

Available Options

- Natural Gas
- Propane Gas
- Butane Gas
- Single and twin tank models

Available Accessories

- N/A

Specifications

Model	J5	J10
External height (mm)	1060	1060
External width (mm)	300	600
External depth (mm)	770	770
No. of tanks	1	2
No. of baskets	1	2
Oil capacity (litres)	14	2 X 14
Net weight unpacked (kg)	46	54
Gross weight packed (kg)	75	91
Shipping volume (m ³)	0.394	0.658
Total heat input Natural (kW)	12.0	24.0
Total heat input Propane (kW)	11.3	22.6
Total heat input Butane (kW)	11.0	22.0
Gas consumption at full rate Natural (m ³ h ⁻¹)	1.14	2.29
Gas consumption at full rate Propane (kg h ⁻¹)	0.81	1.62
Gas consumption at full rate Butane (kg h ⁻¹)	0.80	1.60
Gas inlet	R _{1/2} (1/2" BSP)	
Btu/h conversion	kW x 3412	

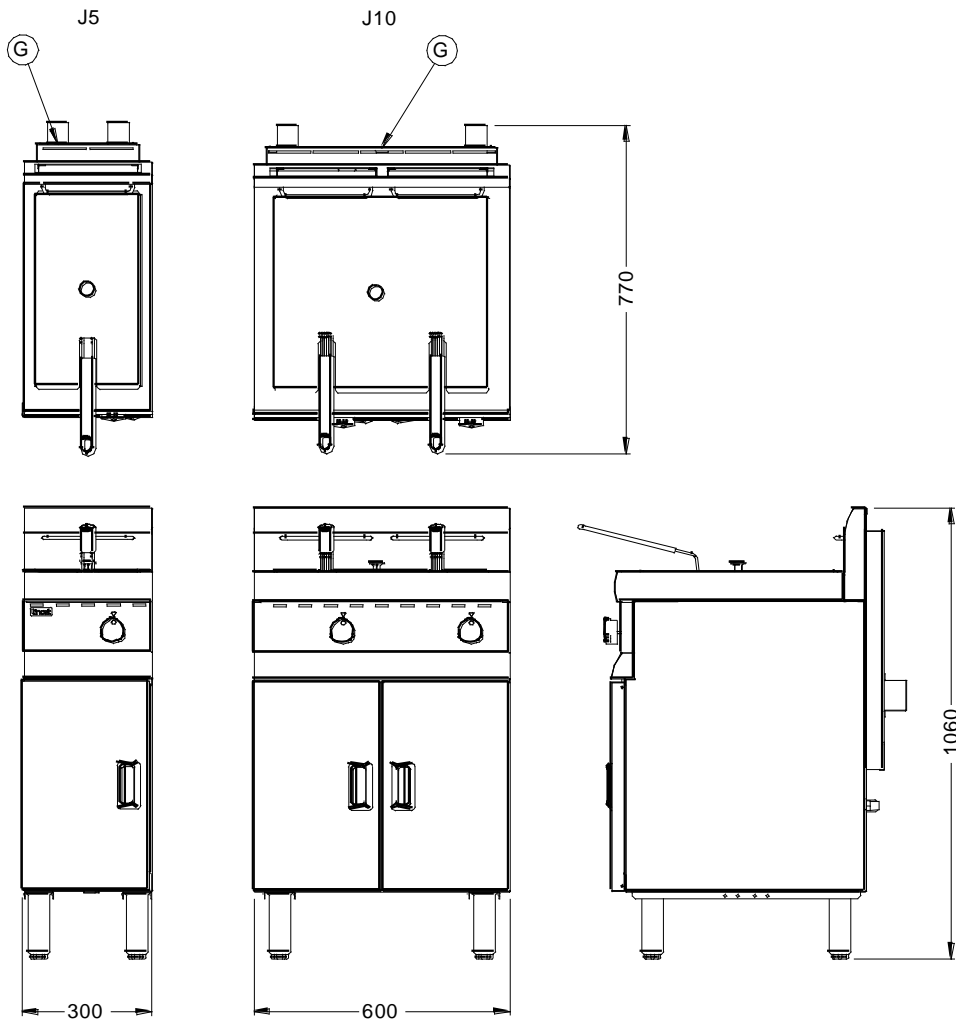

Lincat Limited, Whisby Road,
Lincoln LN6 3QZ,
United Kingdom

UK Sales Tel: 01522 875500 UK Spares Tel: 01522 875510 UK General Tel: 01522 875555
 UK Fax: 01522 875530 International Sales Tel: +44 1522 503250 International Fax: +44 1522 875530
 Website: www.lincat.co.uk UK Sales e-mail: sales@lincat.co.uk International Sales e-mail: export@lincat.co.uk



Document ref:
SLINKJ5_J10
Issue date: Feb-17